



# JKMATIC

## — PRODUCTS CATALOGUE



BENEFITTING SOCIETY / DEVOTION TO BUILD TRUST

HARD WORK BRINGS SUCCESS / SELF DISCIPLINE



BEIJING KANGJIE ZHICHEN WATER TREATMENT CO.,LTD.

Add:NO.5 Huaiying Street,Shahe Industrial Zone,  
Changping District,Beijing,China  
Post code:102206  
Tel : 0086-10-69730336  
Market:0086-10-61703556  
Fax:0086-10-80706936  
E-Mail:kj@kangjiezc.com  
<http://www.kangjiezc.com>





### MILESTONE:

Since JKMATIC was set up for 30 years, has been committed to researching and developing new products, new materials and new equipment in environmental protection area.

#### 2018/2019

Participating in drafting of «Water Quality for Industrial Boilers» GB/T1576-2018 and «Running Results and Monitoring of Industrial Boilers Water Treatment Equipment» GB/T16811-2018; Cooperation with Urban Heating Association of China, applied counter current full-room bed water softener equipment in heating companies.

#### 2014/2015

Cooperation with tens of international companies put products into international market and set up strategy partner relationship with famous companies of agricultural in China.

#### 2010

The first company researched NO POWER automatic control multi-way valve and promoted disc filter totally. Cooperation with WU HAN University set up water treatment technology research laboratory to researching and developing new material, new product, new technology and nanometer film material for water treatment.

#### 2016/2017

Serve many projects of "ONE BELT ONE ROAD" with cooperation of dozens of Chinese project companies. R&D counter-current regeneration full-room bed technology.

#### 2012/2013

Expanded the diaphragm valve to 8 series and scores of styles also used to more wide water treatment area. And successful researched disc filter to suiting sea water desalination in water pretreatment.

#### 2008

Achieve sales revenue 150 million RMB

#### 2005/2006

Achieve sales revenue 80 million RMB, Cooperation with American Pentair Company set up Pentair JIE MING water Treatment Company

#### 1998

The first company introduced the world's advanced technology —hydraulic drive valve into China.

#### 1996

The first company got FRP production line of tank and gone into operation.

#### 2000/2003

The first company researched disc filter and multi-valve system independent and gone into operation already.

#### 1997

The first company introduced the technology of disc filter into China

#### 1994

The first company introduced the technology of automatic Multi-way control valve into China.





# CATALOGUE

COMPANY CULTURE & OPERATION .....	03
DISC FILTER .....	07
MANUAL FILTER .....	15
DIAPHRAGM VALVE .....	18
BACKWASH VALVE .....	22
STAGER AND STAGER CONTROLLERS .....	24
JKTT FLOW METER .....	37
BUTTERFLY VALVE .....	38
JKM DOSING EQUIPMENT .....	55
JK-225 SCALE AND CORROSION INHABITOR .....	58
SHALLOW MEDIA FILTER .....	59
CARTRIDGE FILTER .....	61
CERTIFICATION .....	63

## COMPANY CULTURE

JKMATIC as an environment protection enterprise, put forward a goal is self -construction and products need green and sustainable development.

All products are energy conservation, emission reduction, advanced technology products around the world.

Self-consumable water rate of JK-matic disc filter arrived 3-5 over one thousand, far less than conventional filtering equipment. (8-15percent)

JKMATIC valve nest system more save water and salt arrived 30%-50% than general valve nest system.

JKMATIC put forward a concept is sponge factory, added millions to investing factory build, Using advanced technology-ground source heat pump to warming, refrigeration, and added millions to build system of rainwater recycling.

Using the free ground to planting, breeding, constituting small green circle economic.





HARD WORK  
BRINGS SUCCESS

SELF  
DISCIPLINE

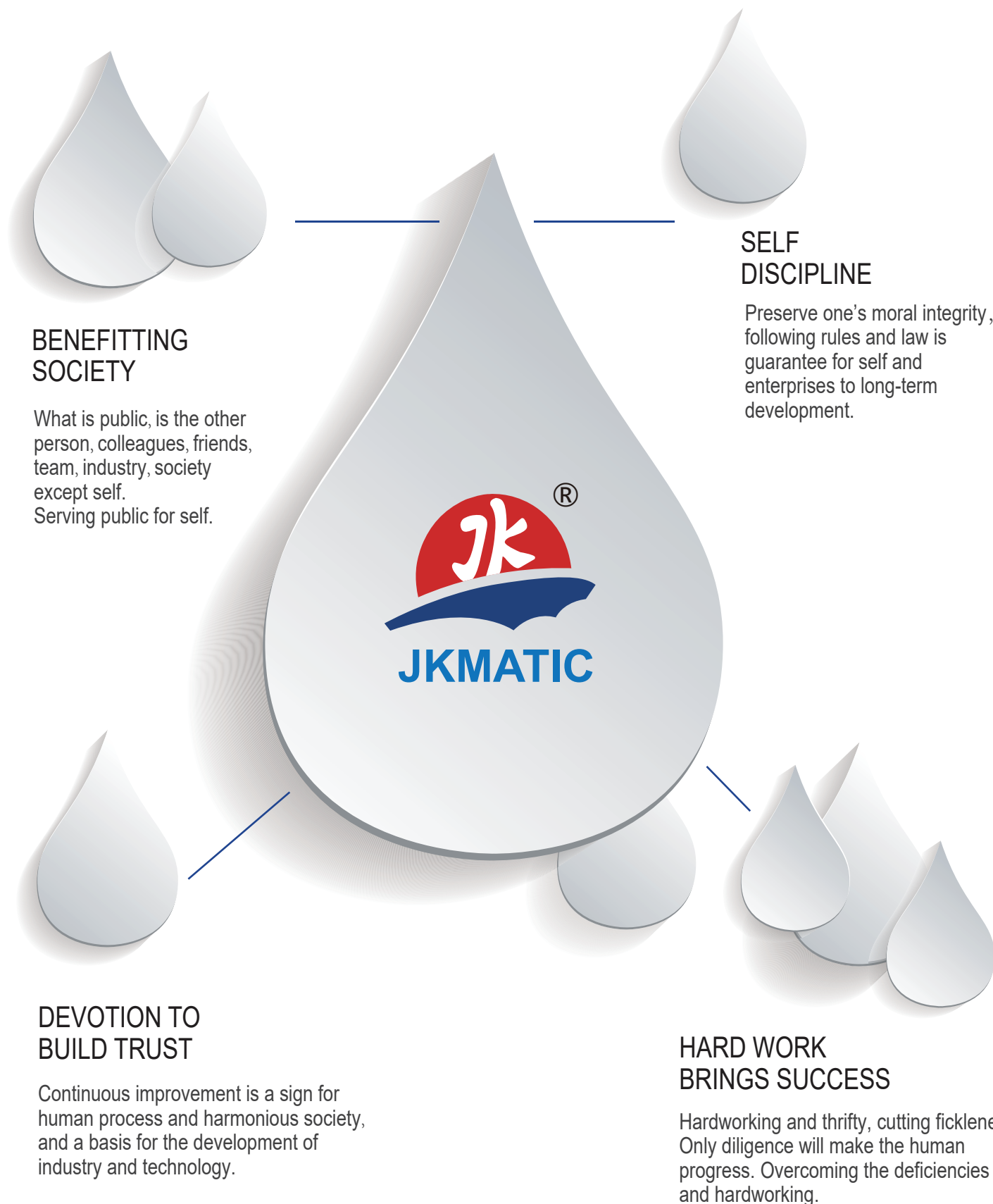

# COMPANY OPERATION

Production workshop, storage, laboratory,  
injection molding workshop, office.

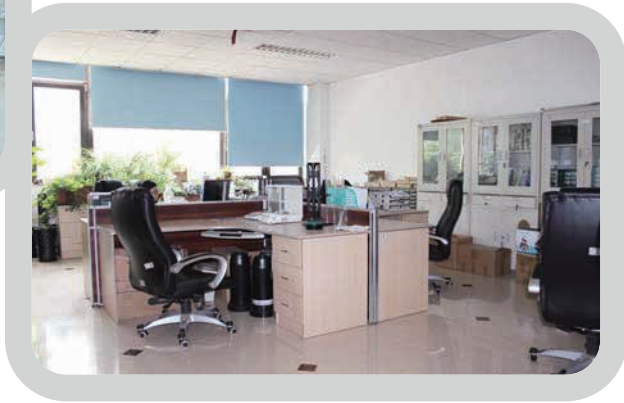



HARD WORK  
BRINGS SUCCESS

SELF  
DISCIPLINE

## Centre of Production and Operation

TECHNOLOGY RESEARCH  
AND DEVELOPMENT CENTER

GLOBAL INTEGRATED SUPPLY CHAIN

LABORATORY

PRODUCTION  
ASSEMBLY WORKSHOP

LOGISTICS  
AND WAREHOUSING  
CENTER

## DISC FILTER

### Technical Advantages

- ✓ **Air Intake & Release Technology**  
Enhance backwash efficiency, save water.
- ✓ **Air Buoyancy Check Valve Technology**  
No metal or rubber contact with water, avoid corrosion or aging.
- ✓ **Hydrocyclonic Technology**  
Enhance filtration and backwash effectiveness.
- ✓ **Quick-lock and Sealing Technology**  
Quick & easy maintenance.
- ✓ **Fully Intelligent & Automatic**  
No complicated control system, easy maintenance.
- ✓ **High Filtration Precision, Highest Precision 5 $\mu$ m, 10 $\mu$ m**

NEW

5 $\mu$ m, 10 $\mu$ m

SLP

Technology

Super Low Pressure

1.2 Bar

Minimum backwash pressure 1.2 bar  
(17 psi), save energy.

NSM

Technology

No Spring and Metal Material

Adopt the NSM technology, no direct  
contact between water and metal,  
excellent corrosion resistance.







High-flux air intake and release valve enhances backwash efficiency, meanwhile the float acts as an indicator.

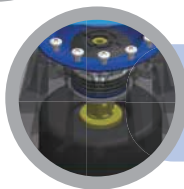

Diaphragm compressing technology is used to compress discs tightly and enable the backwash pressure as low as 1.5 bar (22 psi).



Plastic check valve design, no potential risk of rubber aging and metal corrosion, etc.



Self-locking device with specially designed sealing rings, quick installation and easy maintenance.



No metal components inside the whole disc filter unit, excellent corrosion resistance, specifically designed for high salinity water and sea water applications.

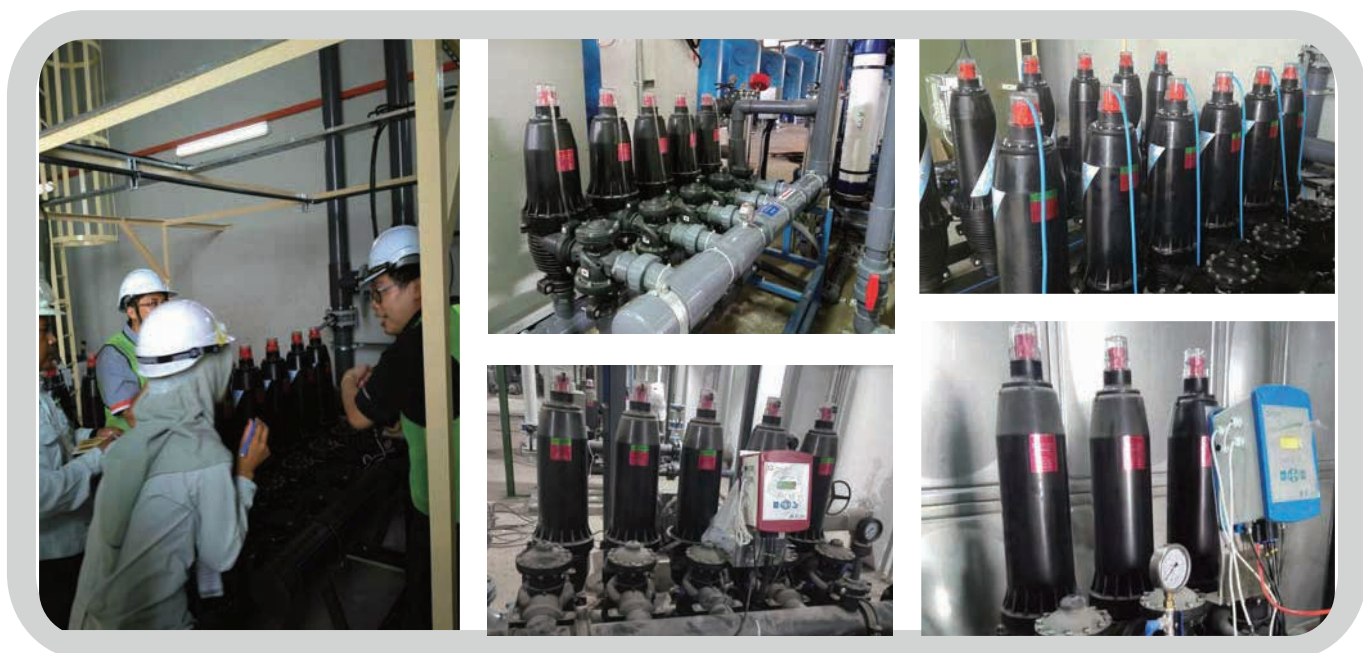

## Operation Principle

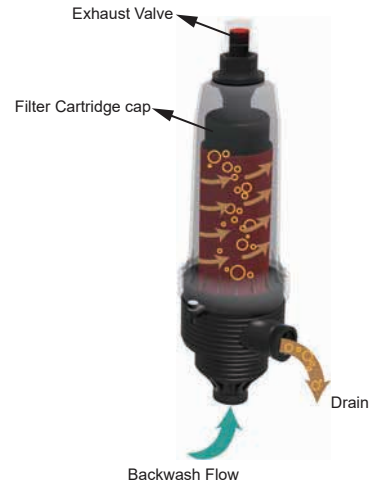

### Working Process

- Water flow from side inlets through the tangent direction to the filter cartridge, inlet water pressure within the chamber drives the diaphragm device that is above the cover, and the mandrel to downward press the disc sets, the disc sets compacted as a filter cartridge, since water impurities intercepted by the filter cartridge, water flow through the check valve locating in the bottom middle of cartridge to the outlet.
- The discs were compressed by the shaft which was pushed by the diaphragm.

### Backwashing Process

- While in backwashing, side inlet becomes drain port, the diaphragm also loses previous downward pressure, meanwhile backwash source water comes from outlet port, because of the check valve, backwash water can only flow through four tubes with nozzles and push upward the filter cartridge cap and diaphragm device, loose the disc sets, meanwhile water flow out through the tangent line, discs rotate, the solid particles were washed out.
- Due to the diaphragm device pushed up, the red indicator upper the cover is pushed out, it is easy to see and determine the inside filter cartridge process from outside.
- While in backwashing, upper automatic air check valve will open automatically, air can come into the chamber, contributed to ejection and washing results improvement.



Technology Company, Nanchang Province

JYP2-4-4 (2 sets)

100m<sup>3</sup>/h



## Design Criterion

Item	Parameter
Max. inlet pressure	8.0 bar
Min. inlet pressure	2.0 bar
Max. working temperature	50 °C
pH	4 - 14

## Materials of Construction

Item	Parameter
Filter housing	Glass fiber reinforced polyamide
Disc	Polypropylene (PP)
Piping	HDPE*/SS304/Carbon steel with anti-corrosive coating
Sealing ring	NBR*/EPDM

Note: \* represents default material.

## Backwash Parameters

Min. backwash pressure per filter unit

1.2 bar(17 psi)

Min. backwash flow rate per filter unit

2.0 L/sec(32 gpm)



Sea Water Desalination Project

JYP3-22 (2 sets)

1000m<sup>3</sup>/h

## Raw water quality classification

**Good water quality:** city tap water, well water extracted from a stable aquifer;

**Normal water quality:** circulating cooling water, the precipitation of treated surface water, after the effective deposition of completely biologically treated drainage;

**Poor water quality:** groundwater extracted from aquifers with poor water quality, groundwater that has been effectively sedimented but has not been or has been subjected to very little biological treatment, and has microbial mass reproduction;

**Very Poor water quality:** well water drawn from dirty or ferromanganese-rich wells, surface water affected by flooding without precipitation, and un-precipitated and biologically treated drainage.]

## Disc Filter Selection Guide

2" filter unit's filtration area =1200cm<sup>2</sup>; 3" filter unit's filtration area=1660cm<sup>2</sup>

Water Quality	Good		Normal		Poor		Very Poor	
	2"	3"	2"	3"	2"	3"	2"	3"
Model No.	2"		3"		2"		3"	
Filtration Grade	Max. Recommended Flow Rate(m <sup>3</sup> /h)		Max. Recommended Flow Rate(m <sup>3</sup> /h)		Max. Recommended Flow Rate(m <sup>3</sup> /h)		Max. Recommended Flow Rate(m <sup>3</sup> /h)	
5μm/2500mesh	5.5	9	4.5	7	3	4.5	1.5	2.5
10μm/1250mesh	6.5	10	5.5	8	3.5	5.5	2	3
20μm/625mesh	7	11	6	9	4	6	2	4
50μm/300mesh	12	17	10	14	7	10	5	7
100μm/150mesh	16	25	14	20	12	17	8	12
130μm/120mesh	20	32	17	27	14	23	9	14
200μm/75mesh	24	36	20	30	16	25	10	16

Note: The above data are based on the testing conditions in laboratory. Please select appropriate mode numbers and filtration grades according to the actual operation conditions or consult local distributors or sales representatives.

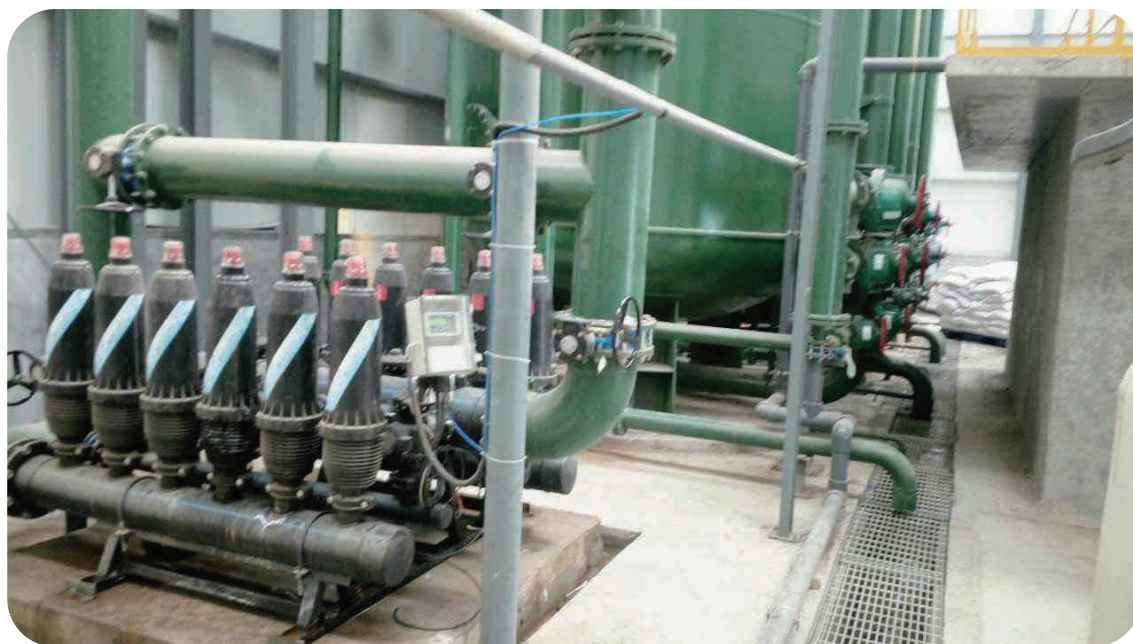

Petrochemical Enterprise, Shandong Province JYP3-12 400m<sup>3</sup>/h

## 2" Filter unit

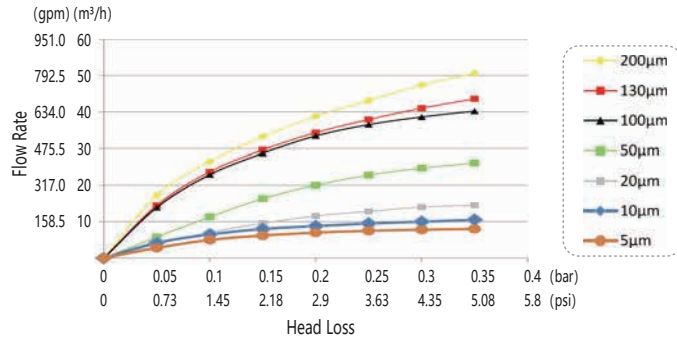

## 3" Filter unit

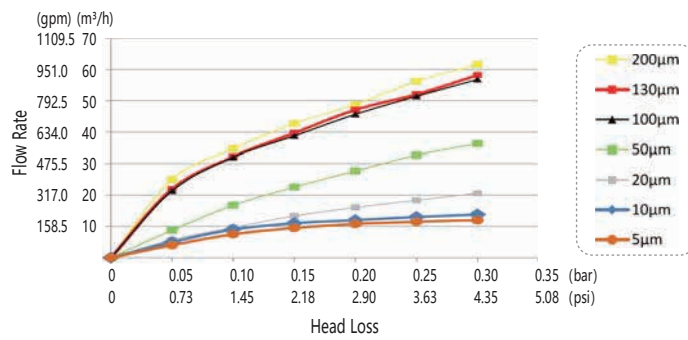

- 200µm (75目)
- 130µm (120目)
- 100µm (150目)
- 50µm (300目)
- 20µm (625目)
- 10µm (1250目)
- 5µm (2500目)



Pharmaceutical Factory,  
Jilin Province

JYP3-10 (4 sets)

300m³/h

# APPLICATION



HARD WORK  
BRINGS SUCCESS

SELF  
DISCIPLINE



# MANUAL FILTER



## Y Type Filter

Being composed of polypropylene engineering plastic, with the features of easy installation, high compression resistance and durability, the Y-filter perform perfectly in reducing frequency of cleaning, blocking particle and impurity effectively and achieving water saving with its sturdiness and durability.



## T Type Filter

In order to face the bigger requirement of volume and performance, We have developed different sizes of T type filter. This type of filter have better performance and more choice of filter element (different mesh of both screen and disc).





## Y Type Filter

Y type disc filter							
Product	Pictures	Model	Max Flow	Coverage	Mesh	Max pressure	Connection & installation type
3/4 inch Y-type filter		JK-YD025-X	5 m <sup>3</sup> /h	180 cm <sup>2</sup>	120	8	3/4" BSP
1 inch Y-type filter		JK-YD032-X	6 m <sup>3</sup> /h	180 cm <sup>2</sup>	120	8	1" BSP
1.2 inch Y-type filter		JK-YD040-X	10 m <sup>3</sup> /h	300 cm <sup>2</sup>	120	8	1-1/4" BSP
1.5 inch Y-type filter		JK-YD050-L	14 m <sup>3</sup> /h	300 cm <sup>2</sup>	120	8	1-1/2" BSP
2 inch Y-type filter		JK-YD063-S	20 m <sup>3</sup> /h	300 cm <sup>2</sup>	120	8	2" BSP
2 inch Y-type filter		JK-YD063-L	25 m <sup>3</sup> /h	525 cm <sup>2</sup>	120	8	2" BSP
2.5 inch Y-type filter		JK-YD075	30 m <sup>3</sup> /h	600 cm <sup>2</sup>	120	8	2-1/2" BSP

Y type screen filter							
Product	Pictures	Model	Max Flow	Coverage	Mesh	Max pressure	Connection & installation type
3/4 inch Y-type filter		JK-YS025-X	5 m <sup>3</sup> /h	180 cm <sup>2</sup>	120	8	3/4" BSP
1 inch Y-type filter		JK-YS032-X	6 m <sup>3</sup> /h	180 cm <sup>2</sup>	120	8	1" BSP
1.2 inch Y-type filter		JK-YS040-X	10 m <sup>3</sup> /h	300 cm <sup>2</sup>	120	8	1-1/4" BSP
1.5 inch Y-type filter		JK-YS050-L	14 m <sup>3</sup> /h	300 cm <sup>2</sup>	120	8	1-1/2" BSP
2 inch Y-type filter		JK-YS063-S	20 m <sup>3</sup> /h	300 cm <sup>2</sup>	120	8	2" BSP
2 inch Y-type filter		JK-YS063-L	25 m <sup>3</sup> /h	525 cm <sup>2</sup>	120	8	2" BSP
2.5 inch Y-type filter		JK-YS075	30 m <sup>3</sup> /h	600 cm <sup>2</sup>	120	8	2-1/2" BSP

## T Type Filter

T type disc filter								
Product	Pictures	Model	Connection	Body Material	Mesh	Max pressure	Max Flow	Size
1.2 inch disc filter		JK-TD040	BSP	Glass-fiber reinforced polypropylene	120	8	10m <sup>3</sup> /h	270×210×135mm
1.5 inch disc filter		JK-TD050	BSP	Glass-fiber reinforced polypropylene	120	8	14m <sup>3</sup> /h	270×210×135mm
2 inch disc filter		JK-TD063-S	BSP/VIC	Glass-fiber reinforced polypropylene	120	8	16m <sup>3</sup> /h	270×210×135mm
2 inch disc filter		JK-TD063	BSP/VIC	Glass-fiber reinforced polypropylene	120	8	20m <sup>3</sup> /h	610×320×220mm
2.5 inch disc filter		JK-TD075	BSP	Glass-fiber reinforced polypropylene	120	8	25m <sup>3</sup> /h	620×320×220mm
3 inch disc filter		JK-YD090	BSP/VIC	Glass-fiber reinforced polypropylene	120	8	30m <sup>3</sup> /h	740×340×220mm

T type screen filter								
Product	Pictures	Model	Connection	Body Material	Mesh	Max pressure	Max Flow	Size
1.2 inch disc filter		JK-TS040	BSP	Glass-fiber reinforced polypropylene	120	8	10m <sup>3</sup> /h	270×210×135mm
1.5 inch disc filter		JK-TS050	BSP	Glass-fiber reinforced polypropylene	120	8	14m <sup>3</sup> /h	270×210×135mm
2 inch disc filter		JK-TS063-S	BSP/VIC	Glass-fiber reinforced polypropylene	120	8	16m <sup>3</sup> /h	270×210×135mm
2 inch disc filter		JK-TS063	BSP/VIC	Glass-fiber reinforced polypropylene	120	8	20m <sup>3</sup> /h	610×320×220mm
2.5 inch disc filter		JK-TS075	BSP	Glass-fiber reinforced polypropylene	120	8	25m <sup>3</sup> /h	620×320×220mm
3 inch disc filter		JK-YS090	BSP/VIC	Glass-fiber reinforced polypropylene	120	8	30m <sup>3</sup> /h	740×340×220mm

# Y52 Series Diaphragm Valve

## Technical Advantages

- ✓ Our diaphragm valves utilize a dual-chamber design to control internal flow. This design makes the control more flexible, reliable and durable, and minimizes switching defects that a single-chamber valve may have.
  - ✓ The valve body and cap are molded with glass fiber reinforced thermoplastic that gives extreme strength, long service life and excellent corrosion resistance. Our diaphragm valves are well suited to demineralization processes.
  - ✓ A special molding process is used to give the reinforced rubber diaphragm extra strength, abrasion resistance and long service life.
  - ✓ The Y-pattern design minimizes pressure loss and increases flow, which results in energy efficient valves.
- Working Pressure: 1 - 8 bar (15-115 psi)
  - Working Temperature: 4 - 50 °C (40-122 °F)



## Specifications

### Male Socket Weld End Connectors

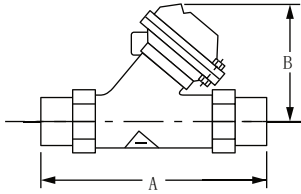

Pipe Size	Units	A	B
1.25"	inches	6.30	3.43
	mm	160.0	87.0

### Grooved Adaptor Connectors

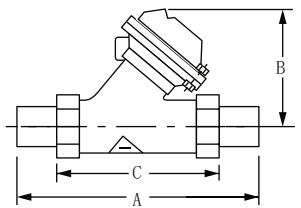

Pipe Size	Units	A	B	C
1"	inches	9.00	4.06	4.50
	mm	228.6	103.1	114.3
1.5"	inches	12.50	5.06	7.75
	mm	336.5	128.5	196.8

### Union End Connectors

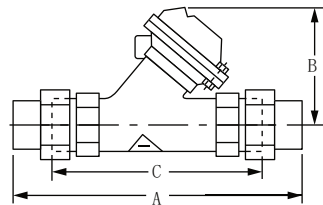

Pipe Size	Units	A	B	C
2"	inches	12.32	5.06	8.78
	mm	313	128.5	223

### Grooved prepared for coupling

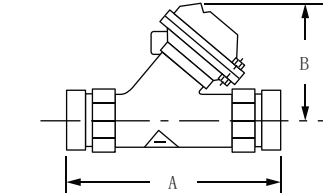

Pipe Size	Units	A	B
2"	inches	7.87	5.06
	mm	200.0	128.5
3"	inches	12.60	8.69
	mm	320.0	220.7

### Female Socket Weld End Connectors

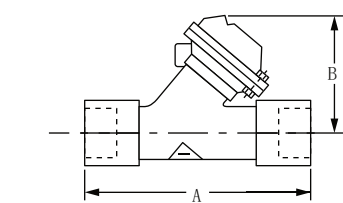

Pipe Size	Units	A	B
1"	inches	6.30	3.43
	mm	160.0	87.0
1.5"	inches	8.35	5.35
	mm	212.0	136.0
2"	inches	10.24	5.35
	mm	260.0	136.0

### Coupling+Socket Weld End Connectors

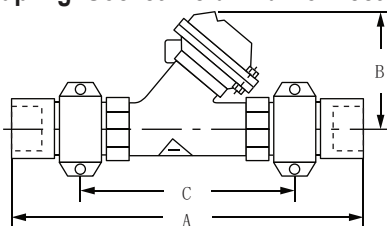

Pipe Size	Units	A	B	C
1.5"	inches	12.83	5.06	7.87
	mm	326.0	128.5	200.0
2"	inches	13.23	5.06	7.87
	mm	336.0	128.5	200.0
2.5"	inches	18.50	8.69	12.60
	mm	470.0	220.7	320.0



Y521



Y524



Y526



Y528

### Flanged End Connectors

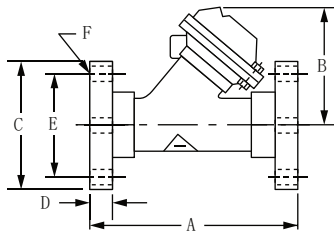

Pipe Size	Standard	Units	A	B	C	D	E	F
2.5"	DIN	inches	11.22	8.69	7.28	0.87	5.71	.71
	/	mm	285.0	220.7	185.0	22.0	145.0	18.0
3"	DIN	inches	12.52	8.69	7.87	0.87	6.30	.71
	/	mm	318.0	220.7	200.0	23.0	160.0	18.0
4"	DIN	inches	12.20	9.37	8.66	.91	7.09	.71
	/	mm	310.0	238.0	220.0	23.0	180.0	18.0
2.5"	ANSI	inches	11.22	8.69	7.28	0.87	5.49	.71
	/	mm	285.0	220.7	185.0	22.0	139.5	18.0
3"	ANSI	inches	12.52	8.69	7.87	0.87	6.00	.71
	/	mm	318.0	220.7	200.0	23.0	152.5	18.0
4"	ANSI	inches	12.20	9.37	8.66	.91	7.50	.71
	/	mm	310.0	238.0	220.0	23.0	190.5	18.0

### Performance Data

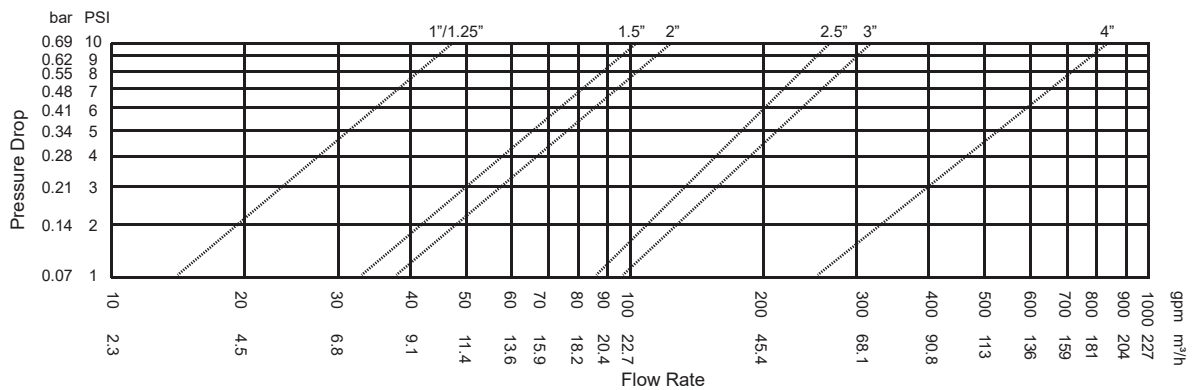

### Principles of Operation

**Normally Open Diaphragm Valve**

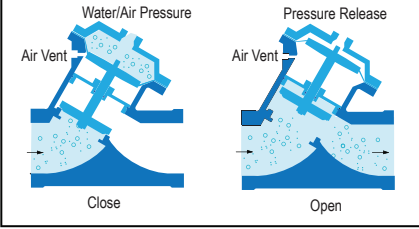
**Normally Closed Diaphragm Valve**

**Limit Stop Diaphragm Valve**

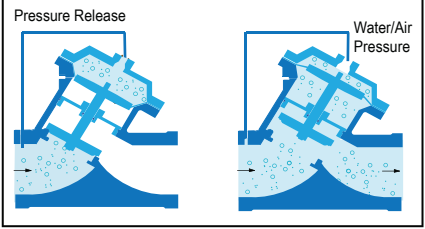
**Spring-assist Closed Diaphragm Valve**

**Position Indicator Diaphragm Valve**

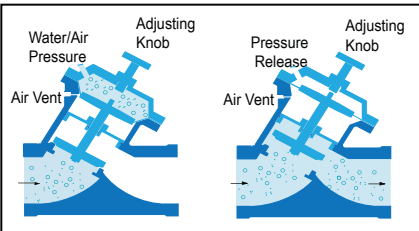
**Spring-assist Open Diaphragm Valve**

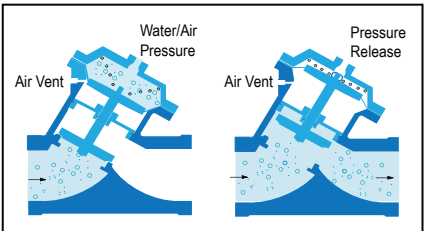
**Solenoid Diaphragm Valve (Normally Closed)**

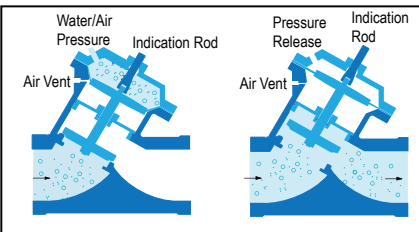
**Solenoid Diaphragm Valve (Normally Open)**

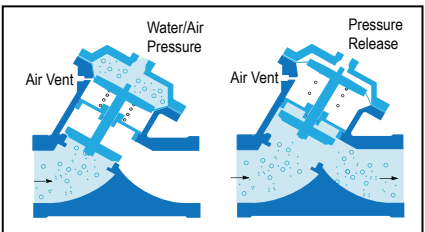
**Signal Switch Diaphragm Valve**

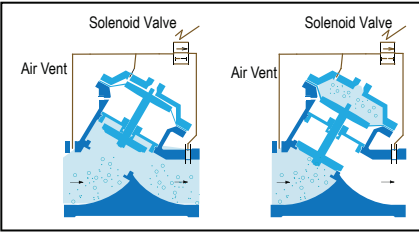
**Liquid Level Control Diaphragm Valve**

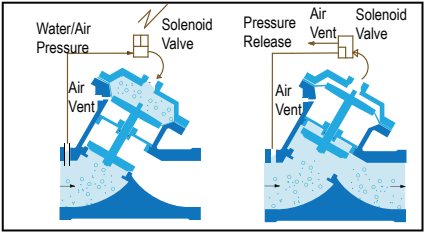
**Pressure Sustaining Diaphragm Valve**

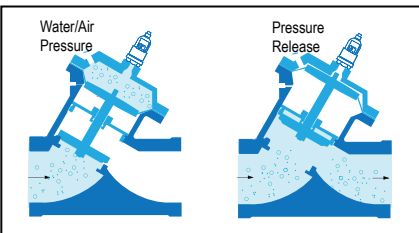
**Pressure Reducing Diaphragm Valve**

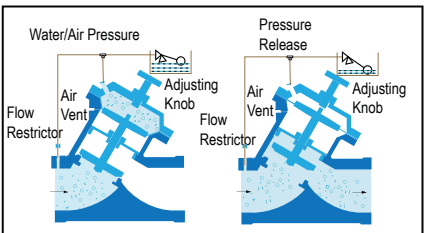
## B Type Filter Backwash Valve

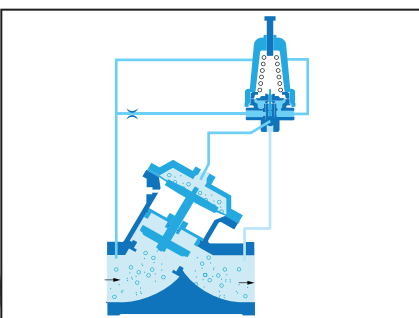

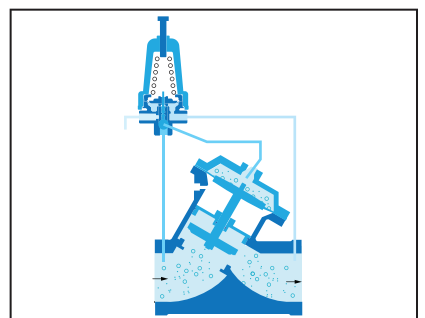
### Technical Advantages

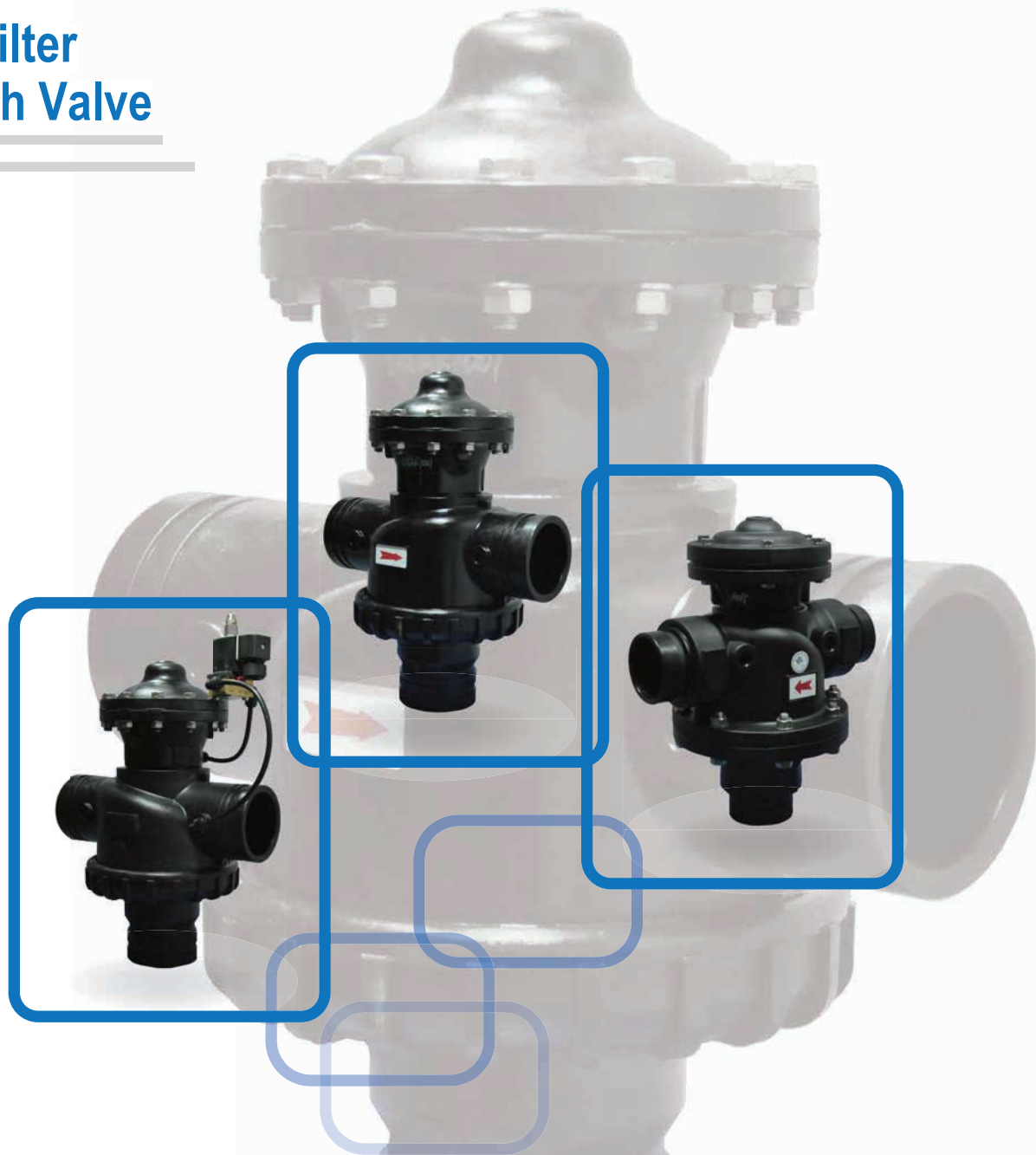
- ✓ The whole valve is made from reinforced PA material, so it is very sturdy and durable.
- ✓ We use a special molding process to enhance the strength of rubber diaphragm and improve abrasion resistance and working life.
- ✓ Every connection port goes with grooved end connection, which enables easy assembly and disassembly.
- ✓ Simple construction, light weight and extra low malfunction rate.

## Principles of Operation

### Angle (A) Flow

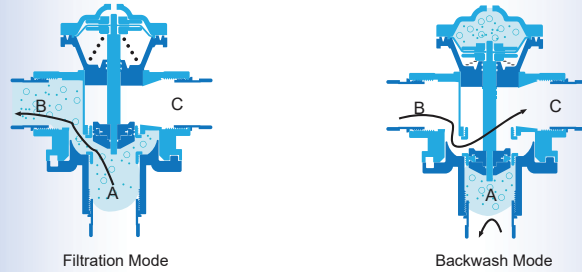

### Straight (S) Flow

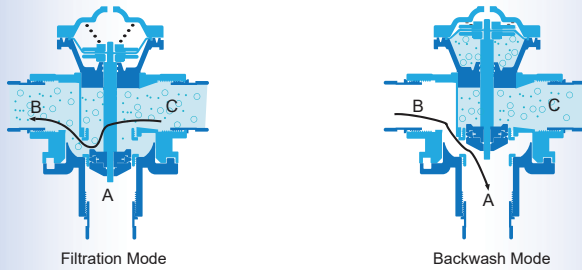

## Specifications

Model No.	Material	Connection Type (Grooved adaptor connectors)	Gross Weight (Kg)	Installation Dimensions L×H×W	
				(mm)	(Inches)
B220A/S	Reinforced PA	2"×2"×2"	2.9	239×276×160	9.4×10.9×6.3
B330A/S		3"×3"×3"	5.2	288×380×194	11.3×15×7.6

■ Working Pressure: 2 – 8 bar (30 – 115 psi)

■ Working Temperature: 4 - 50 °C (40-140 °F)

## Performance Data

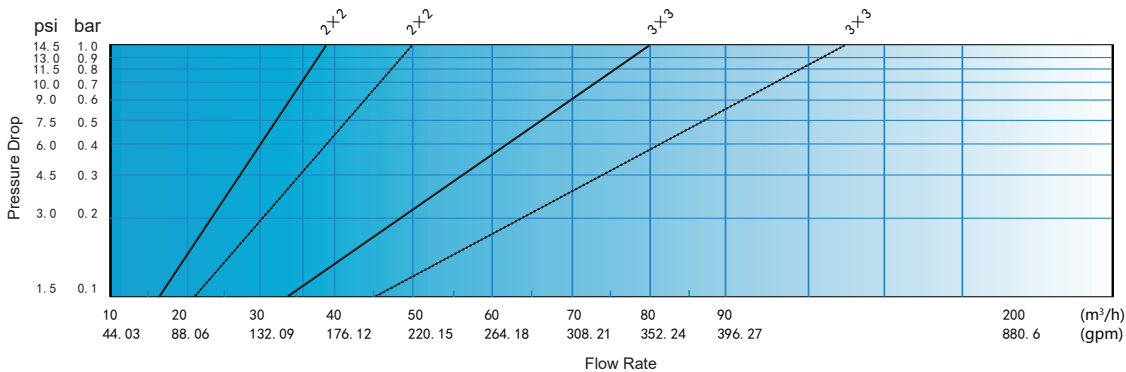

Filtration Mode ———  
Backwash Mode ·····



## Stager and stager controller



### Technical features

- ✓ A motor rotation driving each output port to control the opening and closing of the diaphragm valve.
- ✓ Simple structure, the rotating mechanism adopts the design of self-lubricating material enhancing durability.
- ✓ Specially designed for diaphragm valves, a stager can control one system. An ideal controlling equipment for diaphragm valve.
- ✓ Operated by either hydraulic pressure or pneumatic pressure. The control pressure must be equal to or greater than the system line pressure.
- ✓ It can realize a variety of water treatment processes and has a wide application.

### Stager technical parameters

Item	Parameter
Maximum working pressure	125psi (8bar)
Control source	Air / Water
Operating	4-60°C
Material of subject	Model 48: PA6+GF
	Model 51:: Brass
	Model 56: PPO+GF
Stem plate material	Model 58:: UPVC
	Ptfe& Ceramic
	Model 48: 6
Quantity of control ports	Model 51: 8
	Model 56: 12
	Model 58: 16
Motor parameter	Voltage: 220VAC, 110VAC, 24VDC
	Power: 4W/6W





## Working principle

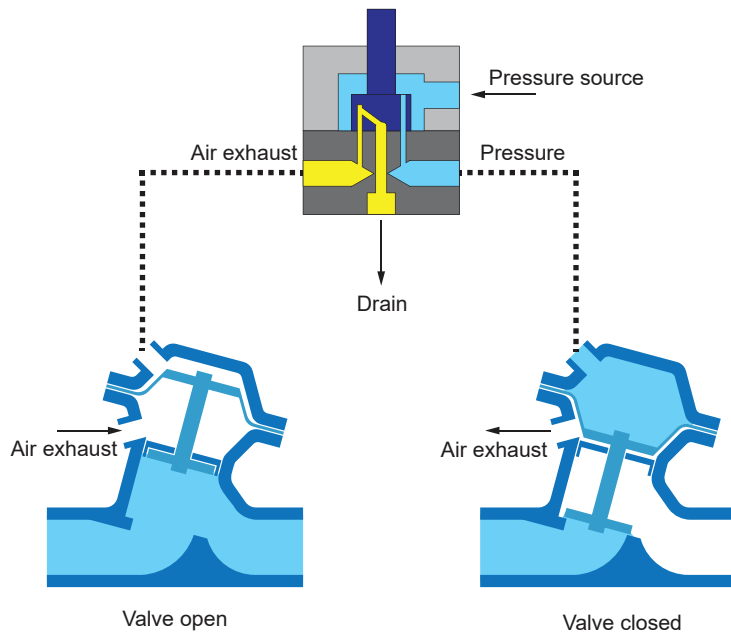

### Stagers applicaion drawings of water softening systems

Cocurrent regeneration softening system(Model 48-502)

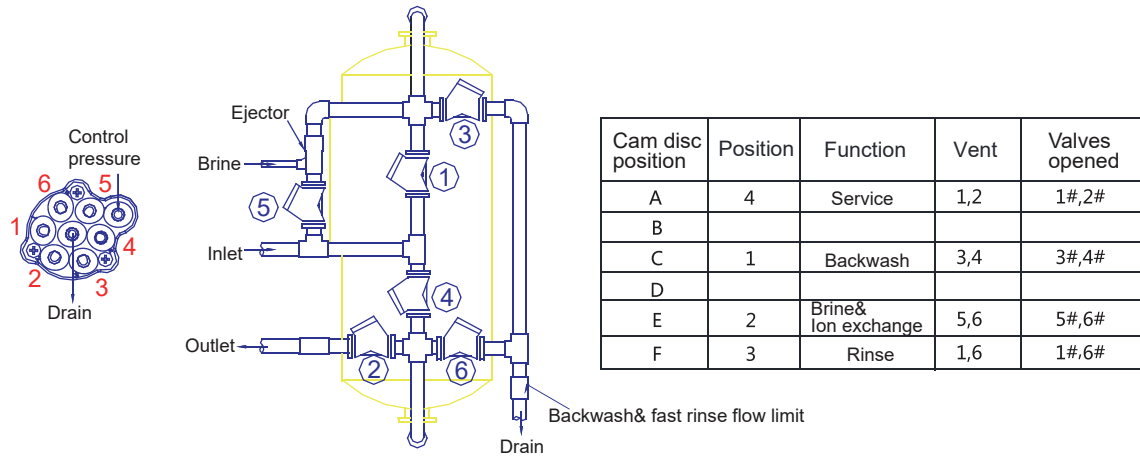

Counter current regeneration softening system(Model 48-505)

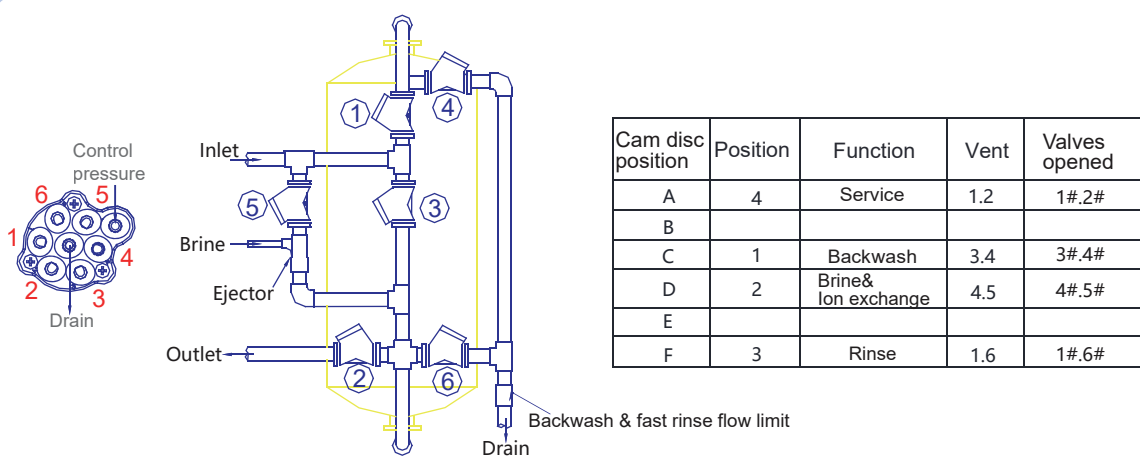



Counter current regeneration softening system (Model 51-520)

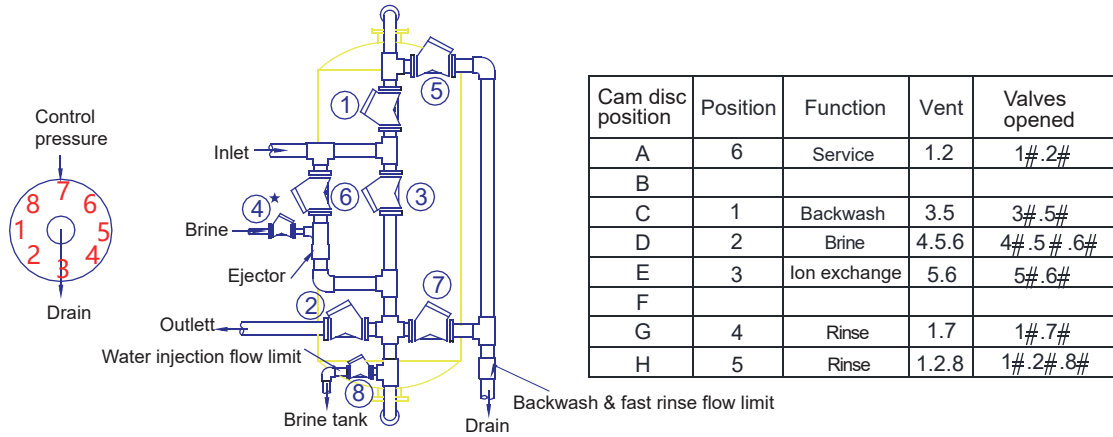

Cocurrent regeneration softening system (Model 51-524)

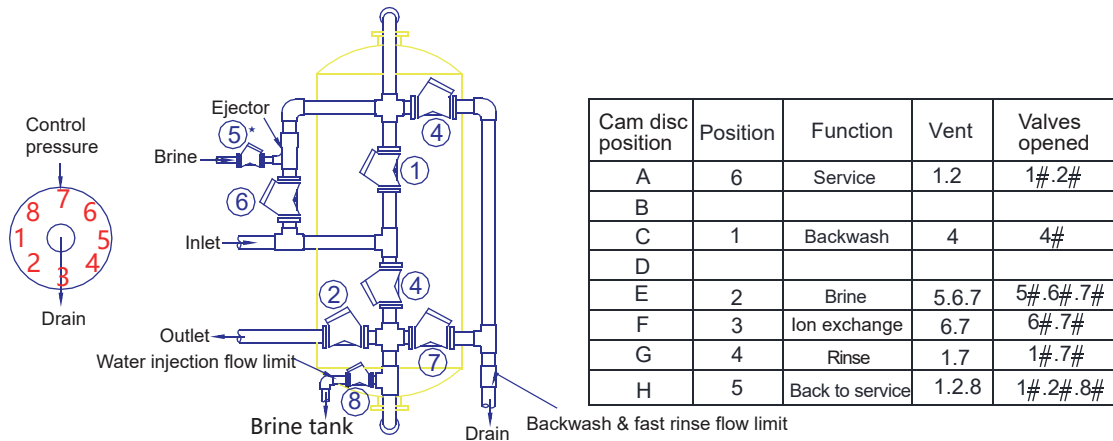

Cocurrent regeneration softening system, one in service, one in standby (Model 58-554)

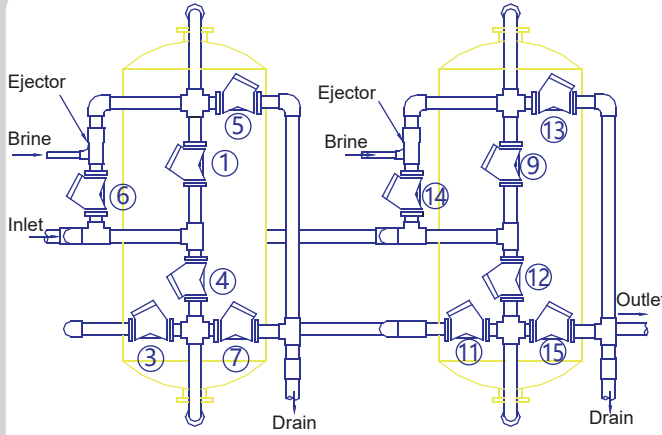

Cam disc position	Position	Function	Vent	Valves opened
A	16	A service B standby	1.3.9	1.3.9
B	1			
C	2			
D	3			
E	4	A backwash B service	4.5.9.11	4.5.9.11
F	5			
G	6	A brine, slow rinse B service	6.7.9.11	6.7.9.11
H	7	A rinse B service	1.7.9.11	1.7.9.11
I	8	B service A standby	1.9.11	1.9.11
J	9			
K	10			
L	11			
M	12	B backwash A service	1.3.12.13	1.3.12.13
N	13			
O	14	B brine, slow rinse A service	1.3.14.15	1.3.14.15
P	15	B rinse A service	1.3.9.15	1.3.9.15

Cocurrent regeneration softening system-alternate regeneration (Model 58-555)

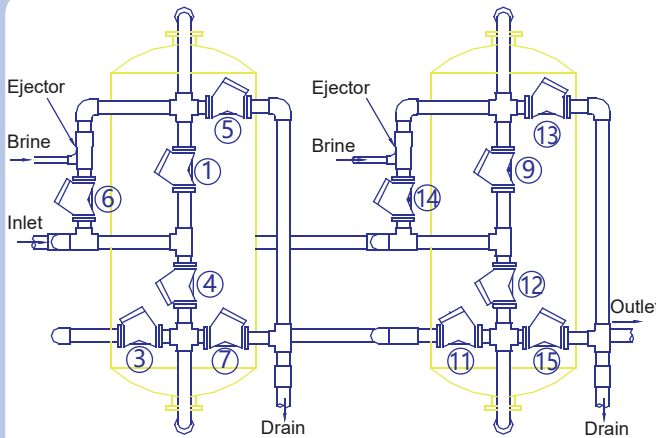

Cam disc position	Position	Function	Vent	Valves opened
A	16	A B service	1.3.9.11	1.3.9.11
B	1			
C	2	A backwash B service	4.5.9.11	4.5.9.11
D	3			
E	4	A brine, slow rinse B service	6.7.9.11	6.7.9.11
F	5			
G	6	A rinse B service	1.7.9.11	1.7.9.11
H	7			
I	8			
J	9			
K	10	B backwash A service	1.3.12.13	1.3.12.13
L	11			
M	12	B brine, slow rinse A service	1.3.14.15	1.3.14.15
N	13			
O	14	B rinse A service	1.3.9.15	1.3.9.15
P	15			



Counter current regeneration softening system- one in service, one in standby (Model 58-556)

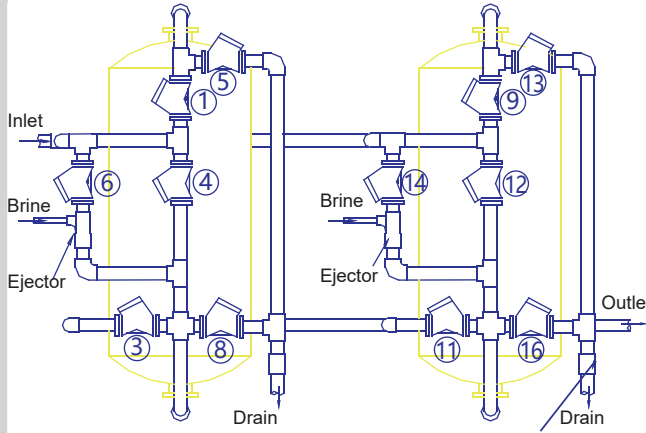

Cam disc position	Position	Function	Vent	Valves opened
A	16	A service B standby	1.3.9	1.3.9
B	1			
C	2			
D	3	A backwash B service	4.5.9.11	4.5.9.11
E	4	A brine, slow rinse B service	5.6.9.11	5.6.9.11
F	5			
G	6			
H	7	A rinse B service	1.8.9.11	1.8.9.11
I	8	B service A standby	1.9.11	1.9.11
J	9			
K	10			
L	11	B backwash A service	1.3.12.13	1.3.12.13
M	12	B brine, slow rinse A service	1.3.13.14	1.3.13.14
N	13			
O	14			
P	15	B rinse A service	1.3.9.16	1.3.9.16

Backwash & fast rinse flow limit

Counter current regeneration softening system-alternate regeneration (Model 58-557)

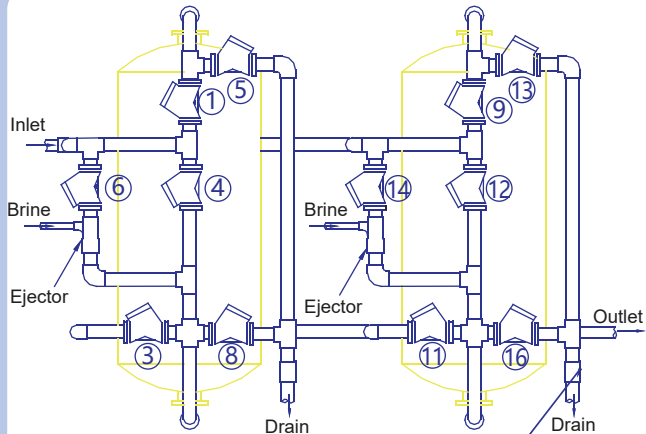

Cam disc position	Position	Function	Vent	Valves opened
A	16	A B service	1.3.9.11	1.3.9.11
B	1			
C	2			
D	3	A backwash B service	4.5.9.11	4.5.9.11
E	4	A brine, slow rinse B service	5.6.9.11	5.6.9.11
F	5			
G	6			
H	7	A rinse B service	1.8.9.11	1.8.9.11
I	8			
J	9			
K	10			
L	11	B backwash A service	1.3.12.13	1.3.12.13
M	12	B brine, slow rinse A service	1.3.13.14	1.3.13.14
N	13			
O	14			
P	15	B rinse A service	1.3.9.16	1.3.9.16

Backwash & fast rinse flow limit



### Stagers application drawings of water filter systems

Filter system (Model 48-501)

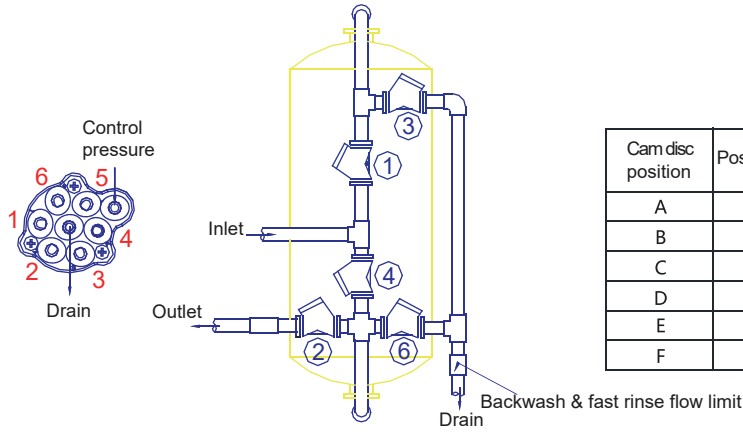

Cam disc position	Position	Function	Vent	Valves opened
A	3	Service	1,2	1#,2#
B				
C	1	Backwash	3,4	3#,4#
D				
E				
F	2	Rinse	1,6	1#,6#

Filter system-3/4/5tanks (Model 48-508)

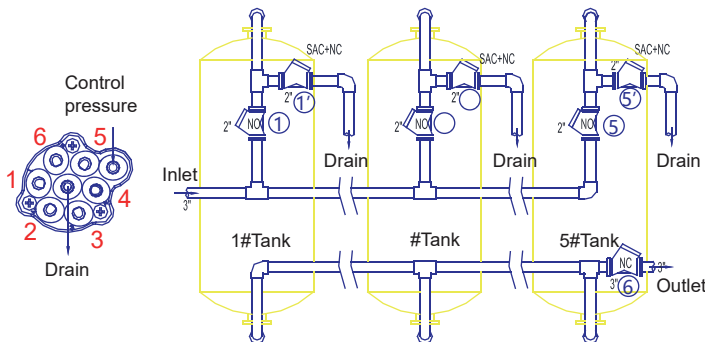

Cam disc position	Position	Function	Valves opened
A	6	Multi-tanks in service	1.2.3.4.5.6
B	1	Tank 1 backwash	1" .2.3.4.5
C	2	Tank 2 backwash	1.2" .3.4.5
D	3	Tank 3 backwash	1.2.3" .4.5
E	4	Tank 4 backwash	1.2.3.4" .5
F	5	Tank 5 backwash	1.2.3.4.5"





Dual tank filtration system (Model 51-527)

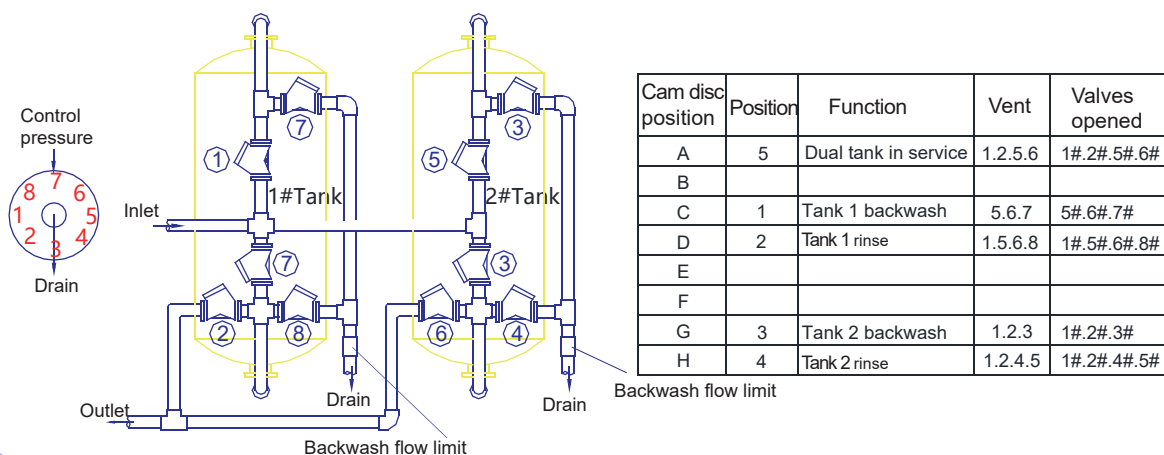

Air wash filtration system (Model 51-528)

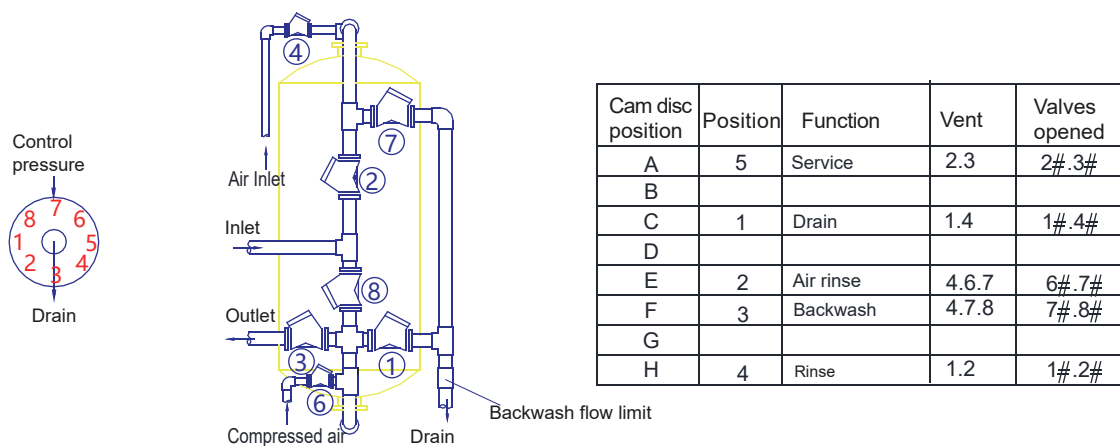

Filter system-6/7tanks (Model 51-531)

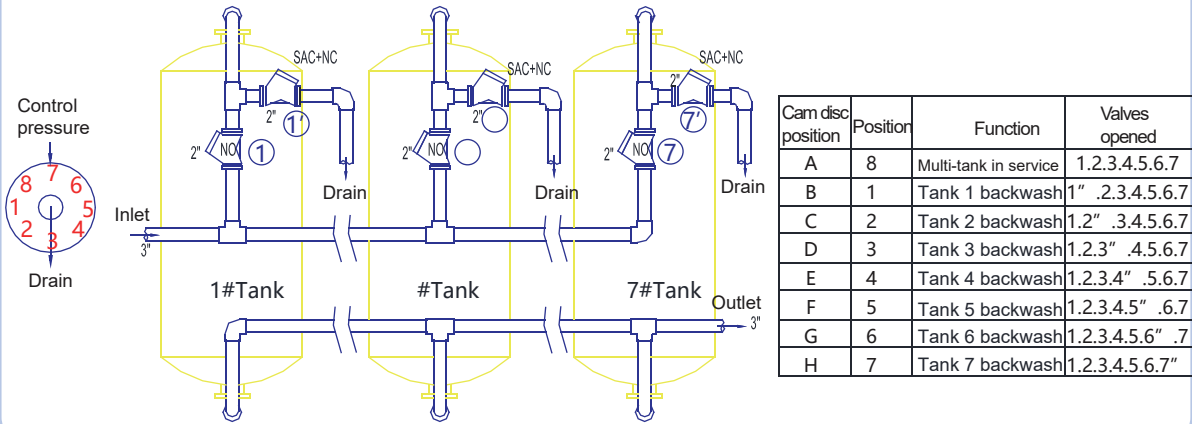

Filter system-one in service, one in standby (Model 51-552)

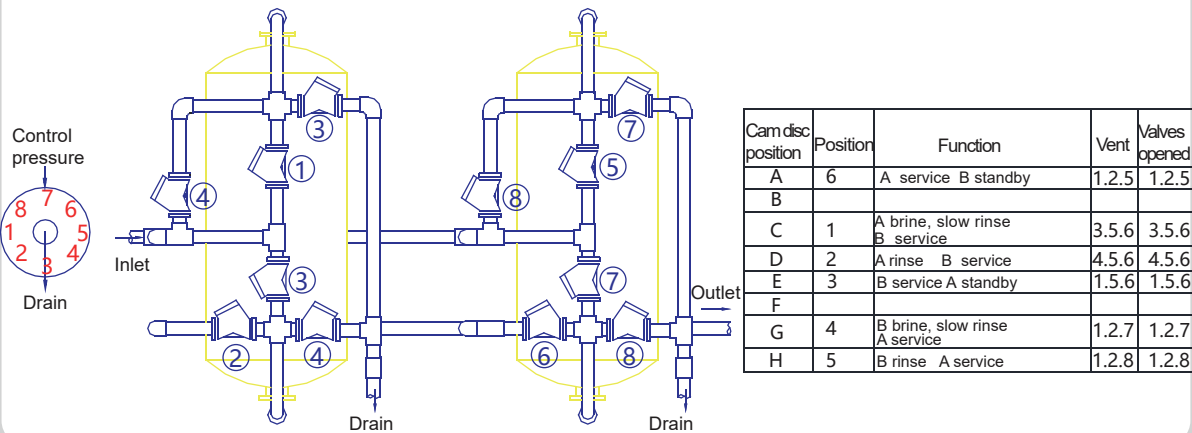



## Stager controller technical parameters

Item	Parameter
Controller Model	JKA2.1 ( Note: CE certification interconnected feature ) JFC2.1 ( Note: built-in differential pressure gauge )
Controller power frequency, power	85-250V/AC、 50/60Hz、 4W
Waterproof grade	IP54
Control pressure	0.2MPa-0.8Mpa
Working environment temperature	4-60°C
Size	174 x 134 x 237
language available	Chinese/ English

JKA2.1: Designed for multi-valve softening and filtration systems

JFC2.1: Specific designed for disc filter system

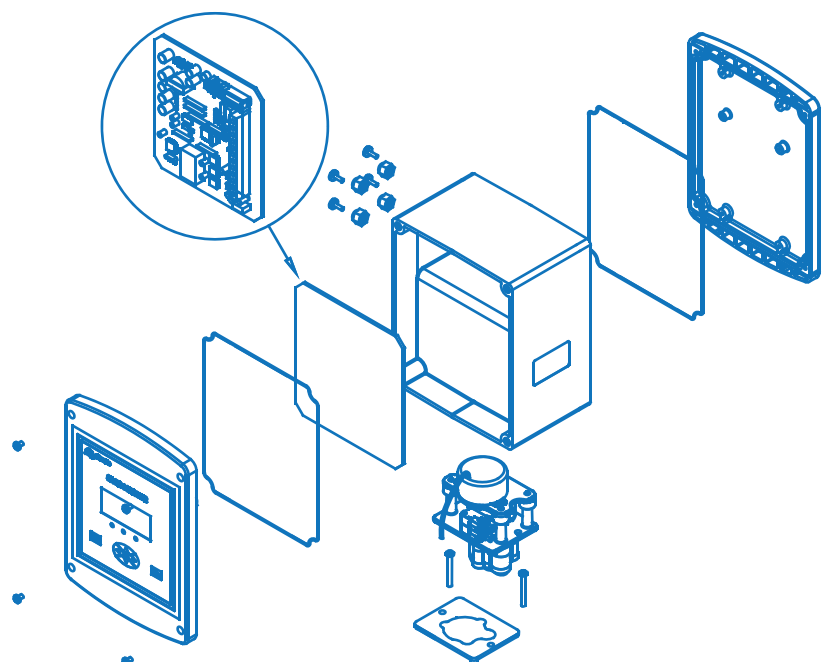

## APPLICATION





HARD WORK  
BRINGS SUCCESS

SELF  
DISCIPLINE



# JKTT FLOW METER

## JKTT Application

- Industrial flow monitoring
- Circulating cooling water flow monitoring
- Nonpotable water flow monitoring
- Flow monitoring after waste water treatment
- Flow monitoring of irrigation
- Monitoring for softening, filtration, multi-valves, and multi-port valves
- Other water flow monitoring and control

## JKTT Flow Sensor Performance Compared with Similar Products

Contrast range	JKTT Flow meter	Similar Products in the Market
Measurement object	liquid	Same
Measuring range	1-5m/s design range 1-3m/s	Same
The best measurement of diameter	DN40 - DN100	Same
Measurement accuracy level	±4% can be used as a measuring instrument	±5%(outside of grade)cannot be used as a measuring instrument
Working power and output power	5-24V/DC, ≤20mA long distance transmission	9-12V/DC, ≤20mA cannot be used for long distance transmission
The longest distance of the signal transmission	Continuous pulse square wave, strong anti-interference properties	The continuous sine wave, strong anti-interference properties
Max. transmission distance	300m	60m
Impeller material	PVDF	Same



HARD WORK  
BRINGS SUCCESS

SELF  
DISCIPLINE

## Butterfly valve



**PRODUCTS PHOTOS COLLECTION**







## Product Selection Instruction

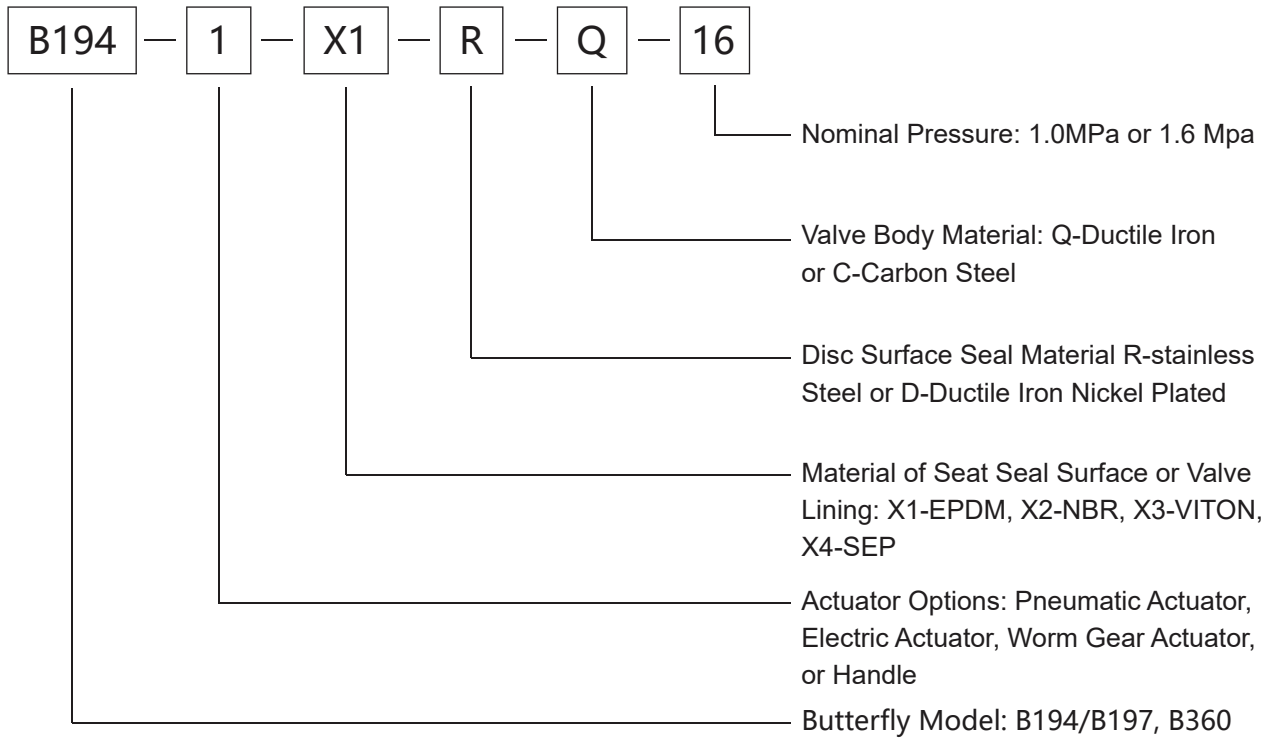

## Parameters

Items Parameter	B194/B197	B360
	Nominal Diameter (mm)	DN50-DN1200
Nominal Pressure (Mpa)	1.0/1.6/150LB	1.0/1.6/2.5/150LB
Shell Test Pressure (Mpa)	Nominal Pressure×1.5	
Seal Test Pressure (Mpa)	Nominal pressure×1.1	
Drive Type	Handle, Worm Gear Actuator, Electric Actuator, Pneumatic Actuator	
Applicable Temperature	-40°C-150°C	



## B194/B197series

Traditional backrest seat with inter  
change ability and low cost



## B194(A-Type Wafer)/B197 (U-Type Wafer) Series Center-Line Butterfly Valve

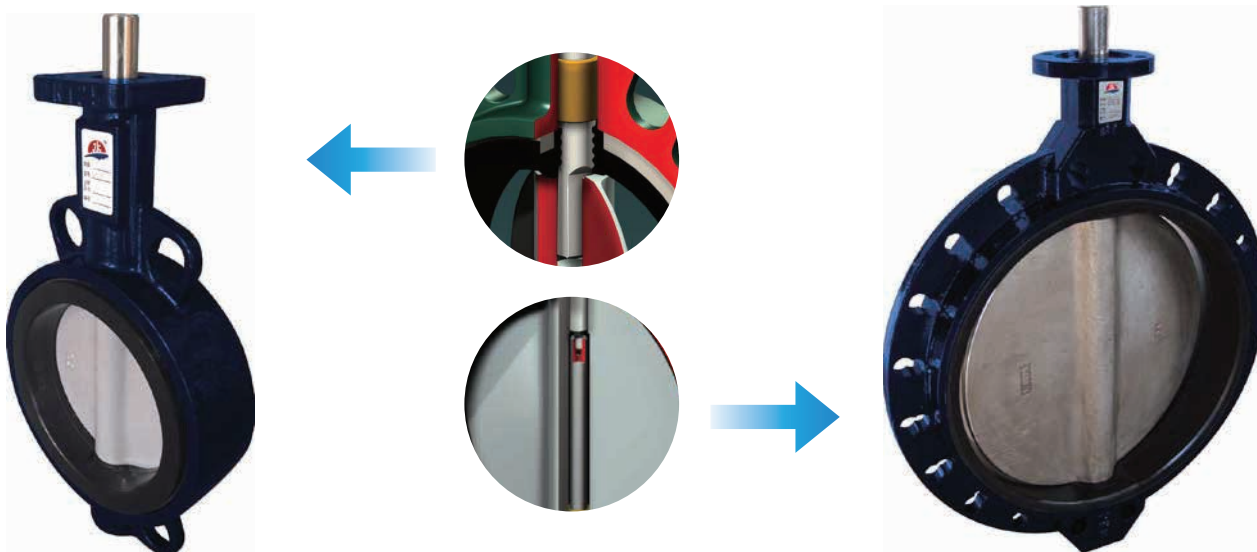

### Features of B194/B197 Series

- Traditional seat with backrest structure, high compatibility and interchangeability, low maintenance cost.
- DN50-DN300 adopts no-pin last shaft connection; DN350-DN1200 adopts two-piece no-pin stems and one intermediate rod. Up stem and down stem are linked together by an intermediate rod, reflecting high bending strength. Thrust bearings are located at the bottom of the stem. The rigidity support brush and self-lubricating brush are adopted at the down shaft hole of disc. This structure is of high rigid and greatly reducing the opening/closing torque.

### Drawing of B194(A-Type Wafer)/B197 (U-Type Wafer) Series

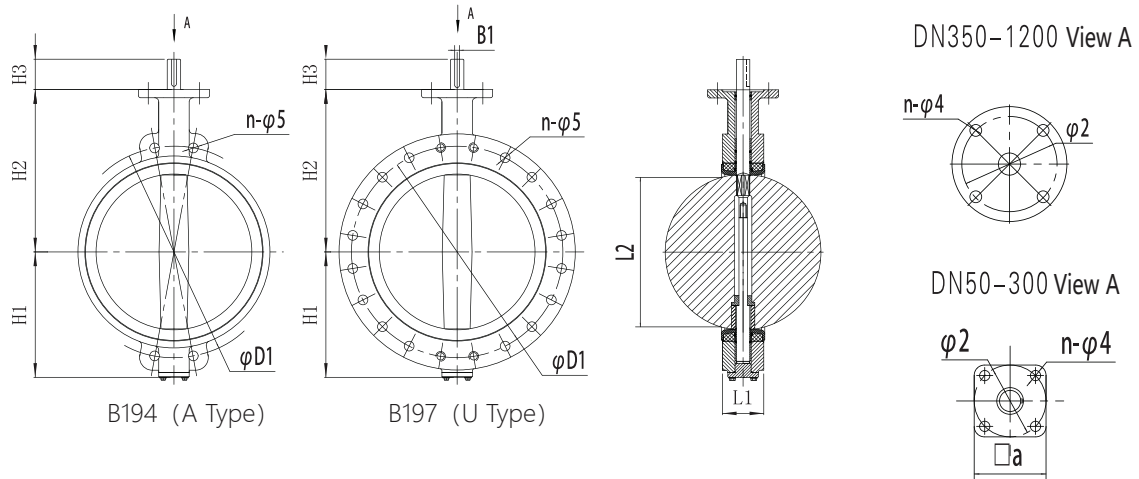

### Dimension of B194 /B197

Specification (mm) (inch)	H1	H2	H3	D1	φ 1	φ 2	□a	n- φ 4	n- φ 5	L1	L2	B1	A-type Net weight (Kg)
50 2"	70	130	22.5	125	12.6	50	50	4- φ 7	4-18	42.6	32	3	2.1
65 2.5"	76	143	22.5	145	12.6	50	50	4- φ 7	4-18	45.6	47	3	2.4
80 3"	89	155	22.5	160	12.6	50	50	4- φ 7	4-18	45.6	65	3	2.6
100 4"	104	170	30	180	15.8	70	70	4- φ 10	4-22	51.6	91	5	4.5
125 5"	120	190	30	210	19	70	70	4- φ 10	4-22	55.6	112	5	6.8
150 6"	139	210	30	240	19	70	70	4- φ 10	8-23	55.6	146	5	22
200 8"	175	243	39	295	22.1	102	95	4- φ 12	8-23 12-23	59.6	194	5	32.2
250 10"	203	282	39	350 355	28.5	102	95	4- φ 12	12-23 12-28	67.6	242	8	45.2
300 12"	242	310	39	400 410	31.7	125	120	4- φ 14	12-23 12-28	77.6	292	8	58.5
350 14"	277.5	368	39	460 470	31.7	125		4- φ 14	16-23 16-28	77	325	10	82.5
400 16"	309	400	51.2 72	515 525	33.15	140		4- φ 18	16-26 16-30	86.5	380	10	86
450 18"	337	422	51.2 72	565 585	38	140		4- φ 18	20-26 20-30	105.6	428	10	109
500 20"	361	480	64.2 82	620 650	41.15	165		4- φ 22	20-26 20-33	131.8	474	10	163
600 24"	459	562	70.2 82	725 770	50.65	165		4- φ 22	20-30 20-36	152	573	16	228
700 28"	527	629	66 82	840	55 63.35	254		8- φ 18	24-30 24-36	163	676	18	334
800 32"	594	666	66 82	950	55 63.35	254		8- φ 18	24-33 24-39	188	773	18	459
900 36"	656	720	118	1050	75	254		8- φ 18	28-33 28-39	203	841	20	600
1000 40"	718	800	142	1160 1170	85	298		8- φ 22	28-36 28-42	216	941	22	973
1200 48"	864	941	142	1380 1390	105	298		8- φ 22	32-39 32-48	276	1127	28	1545

PS: values in table are shown as PN1.0 MPa/PN1.6Mpa



HARD WORK  
BRINGS SUCCESS

SELF  
DISCIPLINE

## B360

Nominal pressure 2.5Mpa



## B360 Series Multifunctional Center-Line Butterfly Valve

### Feature of B360 series

- A short bracket is mounted under the upper flange of the valves, the upper flange is higher than connecting flange 25mm, and the space of pipe network can be reduced effectively. As long as the diameter of the exterior insulation layer of the pipeline is less than the diameter of connecting flange, manual, electric, pneumatic butterfly valves are optional.
- Compact structure, greater compression strength, up to 2.5MPa

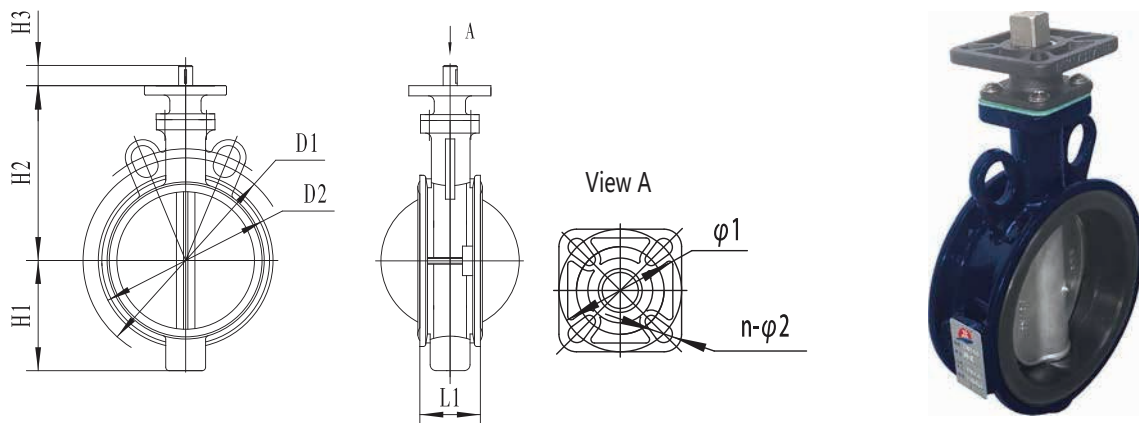

### Dimension of B360 Series Ordinary Butterfly Valve

Specification (DN)		H1	H2	H3	D1	D2	L1	φ1	N-φ2
(mm)	(inch)								
25/32	1 "	41	92	18	PN1.0MPa/PN1.6MPa/GL150/ JIS10K	70	32.7	36/42	4-φ6
40	1.5 "	45	98	18		80	32.7	36/42	4-φ6
50	2 "	53	110	22.5		88	42.6	50	4-φ7
65	2.5 "	65	120	22.5		106	45.6	50	4-φ7
80	3 "	75	131	22.5		120	45.6	50	4-φ7
100	4 "	94	155	30		146	51.6	70	4-φ10
125	5 "	113	170	30		176	55.6	70	4-φ10
150	6 "	124	188	30		207	55.6	70	4-φ10
200	8 "	157	236	39		258	59.6	102	4-φ12
250	10 "	188	278	39		313	67.6	102	4-φ12
300	12 "	227	314	39	368	77.6	125	4-φ14	

amount used when filtering

## Commonly Used, Upper Flange Standard And Torque Value of Butterfly Valve

### Opening and Closing Torque Values of Center-Line Butterfly Valve (N.m)

Specification	Pressure	25 /32	40	50	65	80	100	125	150	200	250	300
Seal DN	MPa											
EPDM	PN1.0	6	8	12	16	21	35	70	80	150	280	400
EPDM	PN1.6	8	10	14	20	26	40	85	90	180	320	460

The torque value listed in the table are measured of room temperature water, excluding safety factor.

### The ISO5211 Connection Dimension Standard Commonly Used In No Drive Device Valve

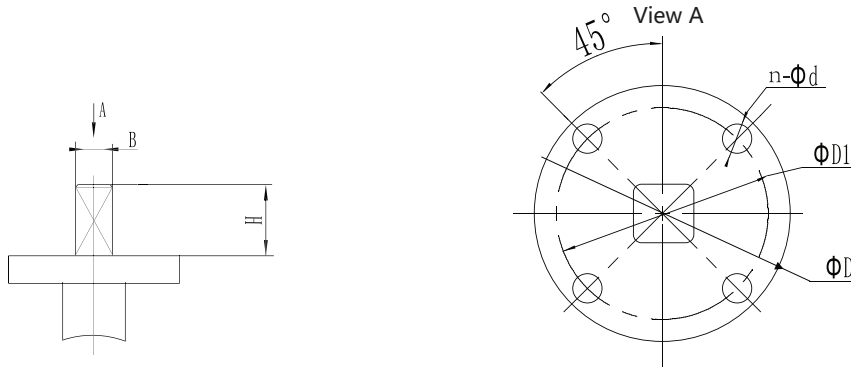

#### Commonly Used Connection Dimension

#### ISO5211 Standard Dimension

Specification	Upper Flange Number	Shaft Size B (Square)	Shaft height H	D	D1	N-Φd	Bolt diameter
DN25	F03-F04	11*11/9*9	12/10	Φ46/Φ54	Φ36/Φ42	4-Φ7	M6
DN32	F03-F04	11*11/9*9	12/10	Φ46/Φ54	Φ36/Φ42	4-Φ7	M6
DN40	F03-F04	11*11/9*9	12/10	Φ46/Φ54	Φ36/Φ42	4-Φ7	M6
DN50	F05	11*11	12	Φ65	Φ50	4-Φ7	M6
DN65	F05	14*14	15	Φ65	Φ50	4-Φ7	M6
DN80	F05	14*14	15	Φ65	Φ50	4-Φ7	M6
DN100	F07	17*17	19	Φ90	Φ70	4-Φ10	M8
DN125	F07	17*17	19	Φ90	Φ70	4-Φ10	M8
DN150	F07	17*17	19	Φ90	Φ70	4-Φ10	M8
DN200	F10	22*22	25	Φ125	Φ102	4-Φ12	M10
DN250	F10	22*22/27*27	25/30	Φ125	Φ102	4-Φ12	M10
DN300	F12	22*22/27*27	30	Φ150	Φ125	4-Φ14	M12
DN350	F12	27*27	30	Φ150	Φ125	4-Φ14	M12
DN400	F14	36*36	40	Φ175	Φ140	4-Φ18	M16
DN450	F14	36*36	40	Φ175	Φ140	4-Φ18	M16
DN500	F16	36*36	40	Φ210	Φ165	4-Φ22	M20
DN600	F16	36*36	40	Φ210	Φ165	4-Φ22	M20

PS: values in the table are JKmatic standard dimensions, and customization available.

### Shape Parameter of Manual Butterfly Valve

Connection Dimension of  
Handle and Valve Body

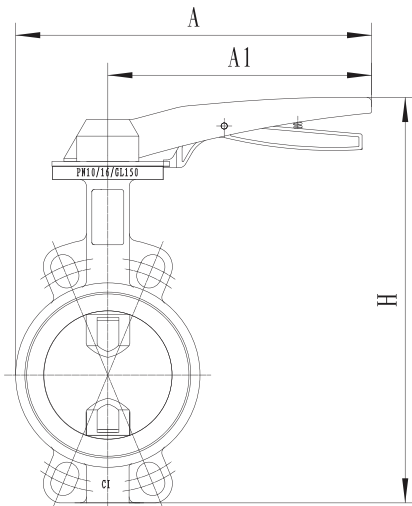

B194/B197

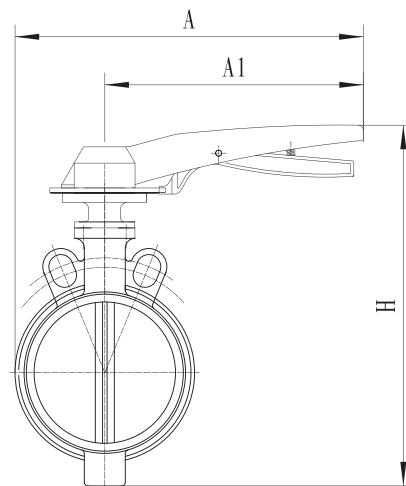

B360

Butterfly Valve Specification	A	A1	H	Net Weight (Kg)	Handle Material
DN50	216	170	260	2.4	Steel Plate
DN 65	223	170	280	2.67	
DN 80	231	170	304	2.87	
DN100	335	200	340	5.00	
DN125	349	260	375	7.3	
DN150	362	260	407	8.8	



Connection Dimension of Worm Drive  
and Valve Body

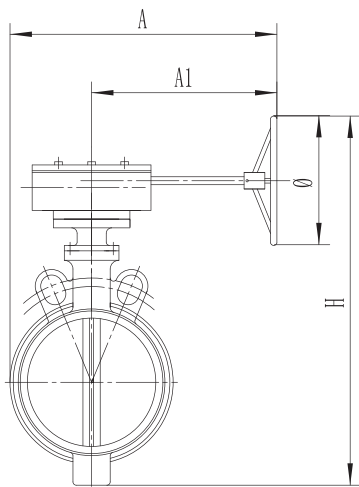

B360

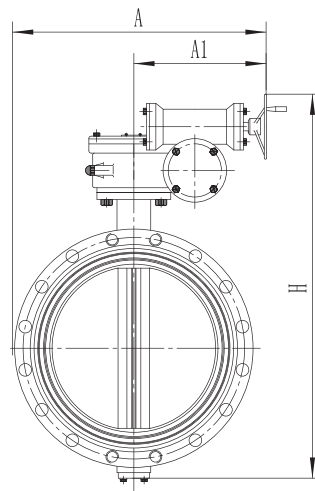

B194/B197

Butterfly Valve Specification	A	A1	H	Φ	Net Weight (Kg)	Remark
DN50	174		306		6.3	
DN 65	181		325		6.6	
DN 80	189		350	120	6.8	
DN100	203	118	380		8.7	
DN125	217		416	160	11	
DN150	230		448		12.5	First-Stage Gear
DN200	354	170	590	220	23.8	
DN250	381		664		29.6	
DN300	403	190	744	280	43	
DN350	429		805		55	
DN400	538		935		89.5	
DN450	564		1004		107.5	
DN500	577		1054		300	
DN 600	754		1189		300	Second-Stage Gear
DN 700	832		1242		400	
DN800	890		1367		400	
DN900	965		1493		300	
DN1000	1030		1636		300	
DN1200	1436		2108		435	

## Shape Parameter of Electric Butterfly Valve

### Connection Dimension of DN50-DN400 Electric Butterfly Valve

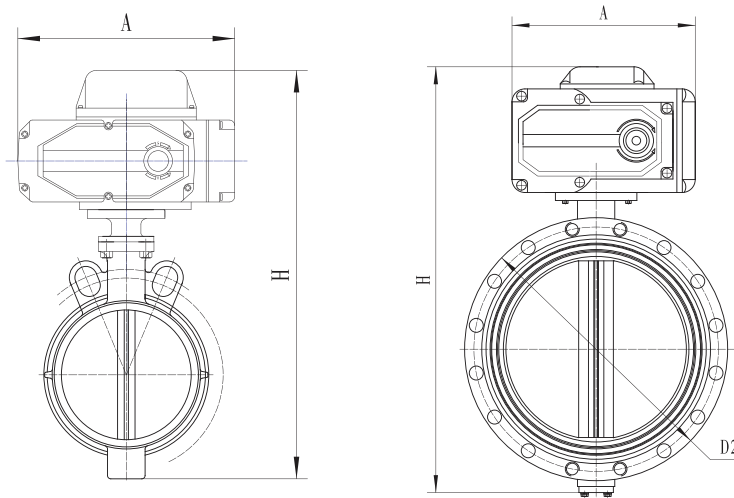

B360

B194/B197



Specification	A		H	
	B194/B197	B360	B194/B197	B360
DN50 2 "	157.5	157.5	303	266
DN65 2.5 "	157.5	157.5	322	288
DN80 3 "	157.5	157.5	347	310
DN100 4 "	207	207	403	380
DN125 5 "	207	207	440	413
DN150 6 "	207	207	472	443
DN200 8 "	256	256	551	534
DN250 10 "	256	256	625	607
DN300 12 "	380	380	719	711
DN350 14 "	380	380	752	—
DN400 16 "	380	380	840	—

### Main Technical Parameters of Electric Devices

Butterfly Valve Specification	DN50 ~ 80	DN100 ~ 150	DN200	DN250	DN300	DN350	DN400
Actuation Time	15S	30S	30S	30S	30S	30S	60S
Actuation Range	0 ~ 90°	0 ~ 90°	0 ~ 90°	0 ~ 90°	0 ~ 90°	0 ~ 90°	0 ~ 90°
Rated Current/ Rated Voltage	0.4A/220V	0.3A/220V	0.45A/220V	0.9A/220V	0.9A/220V	1.7A/220V	1.7A/220V
Motor Protection	Recessed Overheating Protection						
Compression Strength	150VAC 1 Minute						
Manual	Attach to The Crank Type Handle						
Protection Class	IP68						
Wiring Interface	PF1/2X1						
Limit Components	Mechanical Type, Limit Switches Type Block Pieces						
Ambient Temperature	-30°C ~ +60°C						

## Shape Parameter of Pneumatic Butterfly Valve

### Connection Dimension of DN50-400 Pneumatic Butterfly Valve

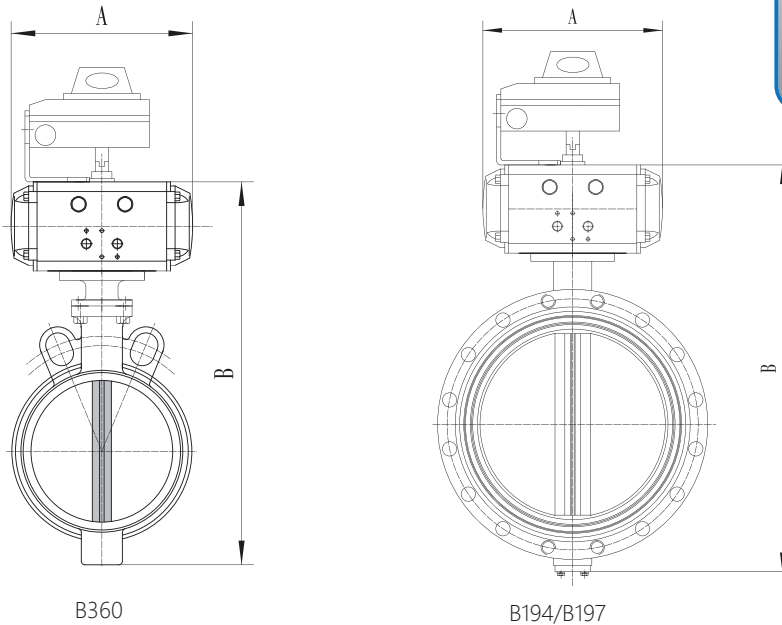

Specification	A		B	
	B194/B197	B360	B194/B197	B360
DN50 2"	141	141	269	232
DN65 2.5"	159	159	304	270
DN80 3"	159	159	329	291
DN100 4"	211	211	376	351
DN125 5"	248	248	425	398
DN150 6"	269	269	469	439
DN200 8"	315	315	555	538
DN250 10"	409	409	661	643
DN300 12"	438	438	745	737
DN350 14"	487	—	831	—
DN400 16"	621	—	973	—

PS: variable values, customization available.

## Actuator Operating Requirements

<b>Operating Media</b>	Wet/dry air or inert gases, any non corrosive gas compatible with the internal components of the actuator and the lubricant.
<b>Air Source Pressure</b>	The highest air source is 8 Bar(116 pound), the lowest air source is 2.5 Bar(36 pound), the common request is 5 Bar.
<b>Operating Temperature</b>	The operating temperature of standard actuator range from -20°C(-40°F) to +80°C(+176°F). higher temperature or lower temperature will change the actuator's output torque.
<b>Stroke Instruction</b>	90° rotation and has a ± adjustable range at the position of 0° and 90°.
<b>Air Source Connection</b>	According to VDI/VDE 2845VAMUR standard, the electromagnetic valve can be assembled simply and conveniently. No need to install piping and fittings.

## Dimension of Bolts of Wafer Butterfly Valve Flange

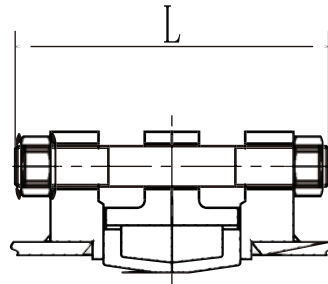

A type butterfly valve bolt connection diagram

Specification (DN)		1.0Mpa			1.6Mpa		
(mm)	(inch)	Qty.	Diameter	L	Qty.	Diameter	L
50	2"	4	M16	130	4	M16	130
65	2.5"	4	M16	140	4	M16	140
80	3"	8	M16	140	8	M16	140
100	4"	8	M16	150	8	M16	150
125	5"	8	M16	150	8	M16	150
150	6"	8	M20	165	8	M20	165
200	8"	8	M20	175	12	M20	175
250	10"	12	M20	185	12	M24	185
300	12"	12	M20	195	12	M24	200
350	14"	16	M20	195	16	M24	200
400	16"	16	M24	220	16	M27	230
450	18"	20	M24	250	20	M27	254
500	20"	20	M24	290	20	M30	294
600	24"	20	M24	324	20	M33	334
700	28"	24	M27	334	20	M33	341
800	32"	24	M30	364	24	M36	375
900	36"	24	M30	388	-	-	-
1000	40"	24	M33	411	-	-	-

PS: 1. GB/T 898-1998 is the applicable standard for double end studs.

2. GB/T 5780-2000 is the applicable standard for hex bolts.

3. 900(36"), 1000 (40") PN1.0Mpa, 700 (28") PN1.6Mpa "A" type valve body are 4\*2 hexagon bolts, number as shown.

## Installation Requirements and Methods for Flange Connection of Center-Line Butterfly Valve

### ID Requirements of Flange

Nominal diameter		Φ max		Φ min
( mm )	( inch )	B194/B197	B360	
50	2"	64	75	47
65	2.5"	76	88	52
80	3"	91	102	70
100	4"	119	130	96
125	5"	140	155	117
150	6"	171	181.5	151
200	8"	220	234	199
250	10"	271	287	247
300	12"	322	341	297
350	14"	354	372	330
400	16"	413	425	385
450	18"	464	477	433
500	20"	513	531	479
600	24"		622	578
700	28"		718	681
800	32"		821	778
900	36"		904	846
1000	40"		1007	946
1200	48"		1220	1132

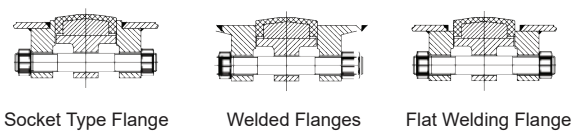
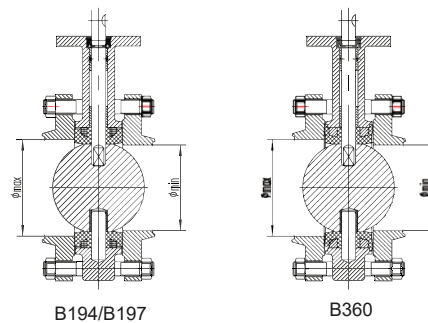

### Requirements of Flange Connection

B194/B197 is adapt to socket type and welded flanges, B360 is adapt to socket type, welded type and flat welding flange.

The flat welding flanges do not apply to most center-line butterfly valves, leaking occur when installed improperly.

### Butterfly Valve Installation

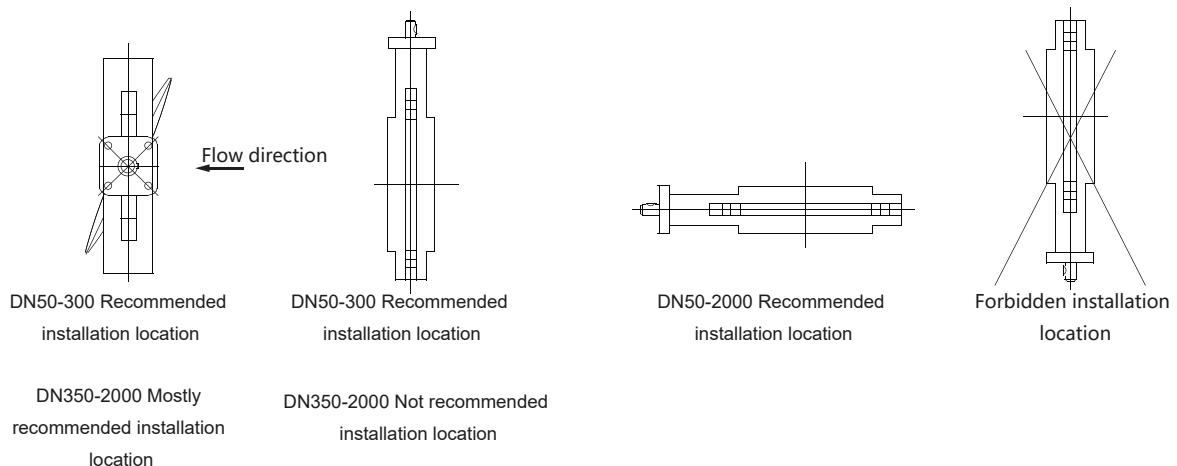

## Valve Common Measurement Unit Conversion and Seal Recommendation Tables

### Valve Common Measurement Unit Conversion

Measurement	Unit System	Unit Name	Unit Symbol	Conversion Relationship	Measurement	Unit System	Unit Name	Unit Symbol	Conversion Relationship
Moment	Metric Unit	Newtonian Meter	N.m	Basic Unit	Pressure	Metric Unit	Pa (ska)	Pa	1Pa=1N/m <sup>2</sup>
	Metric Unit	Gram Force	gf	9.80665x10 <sup>-3</sup> N		Metric Unit	MPa(ska)	Mpa	1MPa=1N/mm <sup>2</sup>
Force	Metric Unit	KG Force	kgf	9.80665N	Metric Unit	Bar	bar	1bar=10 <sup>5</sup> Pa	
	Metric Unit	Newtonian	N	Basic Unit	Metric Unit	Standard atmospheric pressure	atm	1atm=101325Pa	
	British unit	Pound Force	lbf	4.448222N 0.4536kgf	British unit		psi	1Psi=1b/in <sup>2</sup> 1Psi=6.895KPa 1Psi=0.006895MPa	

### Pound and Nominal Pressure Conversion Table (Reference)

Pound	150	300	400	600	800	900	1500	2500
Nominal pressurePN/MPa <sup>+</sup>	2.0	5	6.8	11	13.0	15	26.0	42

### Valve Specification in Metric System and in British System Conversion Tale

mm	15	20	25	32	40	50	65	80
Inch	1/2"	3/4"	1"	1 1/4"	1 1/2"	2"	2 1/2"	3"
mm	100	125	150	200	250	300	350	400
Inch	4"	5"	6"	8"	10"	12"	14"	16"
mm	450	500	600	700	800	900	1000	1200
Inch	18"	20"	24"	28"	32"	36"	40"	48"

### Seal Applicable Media and Temperature Tables

Seal material	Applicable Temperature/°C	Media type and applied degree													Prominent Feature	
		Fresh water	Sea water	Salts	Strong Alkali	Weak alkali	Strong acid	Weak acid	Natural gas	Alcohol	Air	Steam	Oil	Food		
Valve seat	Buna-N	-10~93	A	A	A	C	A	D	B	A	C	A	D	A	B	Oil resistance
Valve seat	HNBR	-30~150	A	A	A	C	A	D	B	A	C	A	A	A	B	High temperature and oil resistance
Valve seat	EPDM	-40~120	A	A	A	C	A	D	A	B	B	A	A	D	A	aging resistance
Valve seat	Heat resistant EPDM	-40~135	A	A	A	C	A	D	A	B	B	A	A	D	A	Heat and aging resistance
Valve seat	Corrosion resistant epdm	-30~135	A	A	A	A	A	A	A	B	B	A	A	D	A	Corrosion and aging resistance
Valve seat	Wear-resisting Ethylene propylene	-30~120	A	A	A	C	A	D	A	B	B	A	A	D	A	Wear-resisting
Valve seat	VITON	-20~204	A	A	A	A	A	C	A	A	C	A	A	A	A	High temperature and oil resistance
Valve seat	SEP	-60~200	A	A	A	A	A	C	A	A	A	A	A	A	A	Sanitary
Valve seat	Neoperene	-40~82	A	A	A	C	A	C	A	A	B	A	A	A	A	flame resistance
Valve seat	PTFE	-20~160	A	A	A	A	A	A	A	A	A	A	A	A	A	Strong corrosion resistance
Butterfly disc	Ductile iron electroplating	-30~350	A	D	C	D	C	D	C	B	A	A	A	A	D	Low price
Butterfly disc	Ductile iron nylon coating	-30~90	A	A	A	A	A	D	A	A	A	A	D	A	A	Resistance to seawater and strong alkali
Butterfly disc	Ductile iron teflon coating	-30~200	A	A	A	A	A	A	A	A	A	A	A	A	A	Strong corrosion resistance
Butterfly disc	Aluminium bronze	-273~232	A	A	C	D	C	D	B	A	A	A	A	A	A	Seawater corrosion resistance
Butterfly disc	SS304	-196~316	A	C	C	C	A	C	A	A	A	A	A	A	A	High temperature and Corrosion resistance
Butterfly disc	SS316	-196~316	A	C	C	C	A	C	A	A	A	A	A	A	A	High temperature and Corrosion resistance
Butterfly disc	SS316L	-196~316	A	B	C	C	A	C	A	A	A	A	A	A	A	High temperature and Corrosion resistance
Butterfly disc	Duplex stainless steel	-268~316	A	A	A	A	A	C	A	A	A	A	A	A	A	High temperature and Corrosion resistance

A Highly Applicable    B Applicable    C Limited Application    D Not Applicable



## CV Value of Center-Line Butterfly Valve

Specifications (DN)		CV value of valve open angles is								CV value as 90° opening
(mm)	(inch)	10°	20°	30°	40°	50°	60°	70°	80°	90°
50	2"	0.1	5	12	24	45	64	90	125	135
65	2.5"	0.2	8	20	37	65	98	144	204	220
80	3"	0.3	12	22	39	70	116	183	275	302
100	4"	0.5	17	36	78	139	230	364	546	600
125	5"	0.8	29	61	133	237	392	620	930	1022
150	6"	2	45	95	205	366	605	958	1437	1579
200	8"	3	89	188	408	727	1202	1903	2854	3136
250	10"	4	151	320	694	1237	2047	3240	4859	5340
300	12"	5	234	495	1072	1911	3162	5005	7507	8250
350	14"	6	338	715	1549	2761	4568	7230	10844	11917
400	16"	8	464	983	2130	3797	6282	9942	14913	16388
450	18"	11	615	1302	2822	5028	8320	13168	19752	21705
500	20"	14	791	1674	3628	6465	10698	16931	25396	27908
600	24"	22	1222	2587	5605	9989	16528	26157	39236	43116
700	28"	36	1813	3639	6636	10000	14949	22769	34898	49500
800	32"	45	2387	4791	8736	13788	20613	31395	48117	68250
900	36"	60	3021	6063	11055	17449	26086	39731	60895	86375
1000	40"	84	4183	8395	15307	24159	36166	55084	84425	119750
1200	48"	106	5370	10741	19641	30690	46065	70587	107568	153450

Note: When the valve is used as open/close type, the rated flow coefficient is selected according to CV value as 90° opening; When the valve is used as adjustment type, the rated flow coefficient is selected according to CV value as 70° opening. Recommended control angle is 25°~70°, optimal control angle is 60°~65°.

### The Conversion Relation with Flux Encumbrance Modulus and CV Va

$$Cv = 29.9 \frac{d^2}{\sqrt{\xi}}$$

d :inside diameter or valve seat caliber(inch)

ξ :flux encumbrance modulus(variab

# JKM Dosing Equipment

## Product Overview

JKM dosing equipment is a series of devices designed for the following applications: feed water dosing during medium and low pressure boiler operation, boiler water adjustment, and circulating water of secondary heating in heat exchange station.

The product is a mechatronics unit with the metering pump as the main body. A set of independent and complete equipment consisting of metering pump, dissolving tank, valve, instrument, pipe, control box according to the certain technical specifications and processflow. It can realize the process of automatic dosing, fault alarm, chain start-stop and remote monitoring of the water supply system.

JKM dosing equipment can provide comprehensive, efficient and economical solutions for boiler feedwater treatment, boiler water control, and heating secondary water circulation system water quality control according to the change of water quality, fully automatic and real-time adding water treatment agent, maximizing the scale inhibition, corrosion inhibition and deoxidization effect of the agent, and thoroughly solving the problems of boiler and heating system fouling, corrosion and water loss.

Models available: standard model JKM-I; economic model JKM-II



## Equipment composition

JKM dosing equipment is composed of dissolving tank, mixer, metering pump, control box and rack ladder.





## Product Features

- ✓ Compact and reasonable structure, Elegant appearance, small footprint.
- ✓ Various water treatment chemicals can be added with high precision, with obvious effect, strong reliability and convenient installation. The user only needs to connect the water inlet and chemical outlet outlet of the device.
- ✓ High degree of automation. The device adopts JKM specific controller controller, low liquid level display and alarm of dissolving tank. system start-stop chain control, microcomputer time control, on-line monitoring instrument adjustment control, remote monitoring.
- ✓ It is easy to operate. Using man-machine dialogue touch screen interface. It can automatically set the time, flow and operating record.
- ✓ Equipped with high-quality metering pump, accurate metering, long service life.
- ✓ A variety of control modes are available.
- ✓ It can be used for both solid and liquid chemicals.
- ✓ The dissolving tank is made of stainless steel or PE material, which is corrosion-resistant and pollution-resistant.

## Scope of application

Feed-water dosing treatment of low-pressure steam boiler.

Reheat station system secondary heating circulating water dosing.

Low-pressure hot water boiler feed water dosing treatment.

Central air-conditioning circulating water dosing treatment.

Medium-pressure hot water boiler feed water dosing treatment.

Dosing treatment of circulating water in the industrial system.

## Technical Parameters

Item	JKM- I Dosing device	JKM-II Dosing device
Mixer Power (KW)	0.75 ~ 1.1	0.37 ~ 1.1
Total Power (KW)	<1.0 ~ <1.65	<0.5 ~ <1.2
Power Supply/ Frequency	380V/50HZ	380V/50HZ

## Model specification

Model	dissolving tank capacity (L)	Metering pump flow range(L/H)	Metering pump pressure range (Bar)	Water recharge volume
JKM- I -500-SS304/PE	500	4.5-25	3.5 ~ 12	< 10 M3/H
JKM- I -1000-SS304/PE	1000	25-50	4.1 ~ 12	< 30 M3/H
JKM- I -1500-SS304/PE	1500	115-237	7 ~ 10	< 50 M3/H
JKM-II-300	300	9	33	< 1 ~ 24 M3/D
JKM-II-500	500	20	33	< 24 ~ 48M3/D
JKM-II-1000	1000	33	33	< 48 ~ 72M3/D
JKM-II-1500	1500	50	33	< 72 ~ 120M3/D

Note: Equipment exceeding the amount of water recharge per hour (or daily) is designed separately.

### JKM-I Product Dimension Diagram

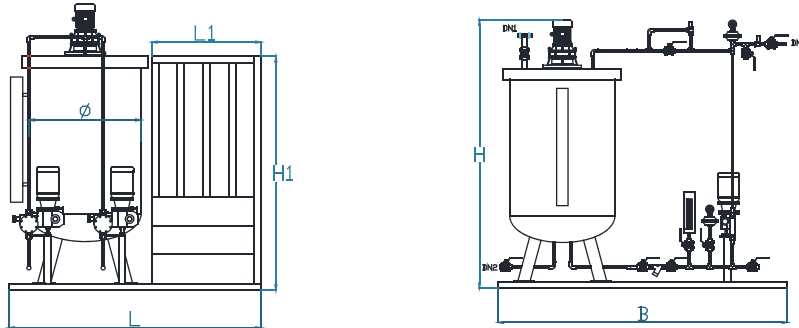

Series	dactylodes	L	L1	H1	H	B	DN1	DN2	DN3	weight (Kg)
JKM-500-SS304/PE	800	1800	780	1650	2100	2000	15	15	15	900
JKM-1000-SS304/PE	1000	2000	780	2000	2600	2000	25	25	25	1200
JKM-1500-SS304/PE	1200	2200	780	2100	2800	2000	25	25	25	1400

### JKM-II Product Dimension Diagram

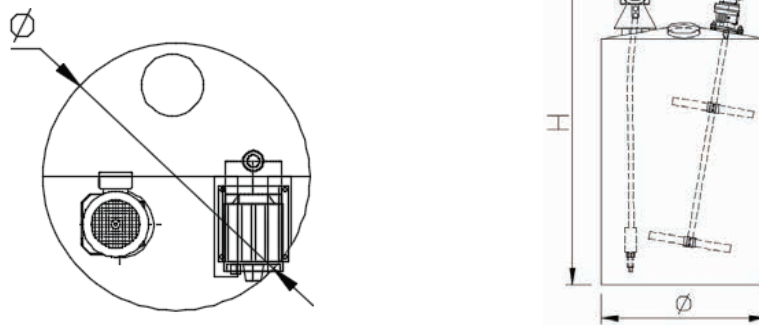

model	Dimension (D*H)mm	Outlet	Power/W	Voltage/V	Netweighe (KG)
JKM-II-300	φ710×1400	15	500	380	50
JKM-II-500	φ790×1450	15	600	380	60
JKM-II-1000	φ990×1550	15	800	380	80
JKM-II-1500	φ1320×1890	15	1200	380	90

### Order Note

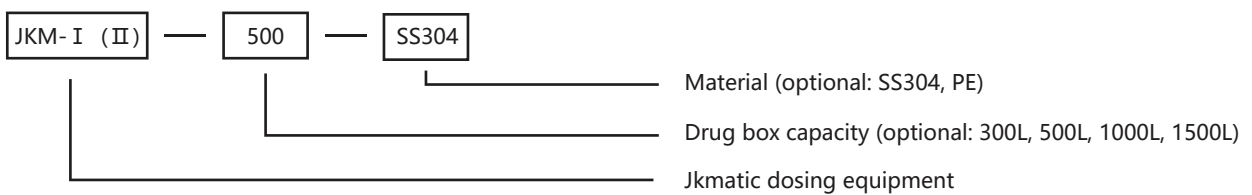

## JK-225 Scale and corrosion inhibitor

Anti-corrosion and anti-scaling; Secure and efficient;  
Green and environmental friendly; Energy efficient and cost saving.

### Technical parameters

Item	Specification
Appearance	Gray solid powder
Density	1.68 g/cm <sup>3</sup>

### Performance and usage

JK-225 scale and corrosion inhibitor is independently developed and patented by JK MATIC. It is the best water treatment chemical that is composed of a variety of organic salts and inorganic salts.

It integrates the function of anti-corrosion and rust, anti-scaling, sterilization and wet protection.

It is specially used for central heating secondary circulation water system.

### How to use

100~200ppm recommended for the first time usage, according to water volume in the closed system, PH remained 9.5-12;

50~100ppm recommended during service, according to the moisture, PH remained 9.5~12;

A central heating system adopts automatic dosing with stirring filter.

### Packaging and storage

JK-225 scale and corrosion inhibitor adopts a larger chemical package 25kg with inside small plastic bags of 5kg each.

Please store in a cool and dry place to avoid moisture absorption and liquefaction.

The storage period is 3 years.

### Safety and protection

Caution! JK-225 scale and corrosion inhibitor solution has obvious burning irritation to the skin; be cautious during operation to avoid contact with skin and eyes, please rinse with plenty of water after contact.



# Shallow Media Filter

- Fully Intelligent & Automatic
- High efficiency of filtration and backwash
- Saving Sand
- Saving Water

## Technical Advantages

- Filter has two large openings. One at the top for viewing and feeding, and the bottom for emptying and maintenance.
- Our unique pressure compensating filter catch-ment has 55 mushroom-shaped ports, the various ports keep the filtration equal and balanced under pressure. In backwash mode it creates a highly efficient; high velocity wash without losing sand through the outlet.
- The filter housing is made of stainless steel, with the inside coated with PE plastic. It has a high weight to pressure ratio, and is highly corrosion resistant, can withstand pressure of 0.59Mpa.
- The black polyethylene filter's inner layer is highly resistant to environmental pressure, preventing embrittlement and chemical erosion.
- Shallow Media Filter system uses time, pressure, and other methods to begin automatic backwash. In automatic operation; each filter unit backwashes sequentially without interruption for continuous production.
- Shallow Media Filter backwash is formed with a turbulence system, high efficiency backwash, backwash time is short, contains water conservation technology (30% less water used than traditional sand filters).
- Easy Installation, small footprint flexible layout (can be rearranged for custom fit of area); light weight of the system, no special foundation is needed, it can be set on a standard concrete floor.



### Specifications

Water Quality Requirements	Water SS≤50 mg/L		Water SS≤5 mg/L
	Filter (12-40 cm thick)	Recommended Flow	Backwash Flow
Prefilter	Quartz sand >2.0 mm	50 - 100 m³/h	50 - 100 m³/h
General Filter	Quartz sand 1.0-2.0 mm	40 - 50 m³/h	35 - 55 m³/h
Fine Filter	Quartz sand 0.1-0.8 mm	15 - 25 m³/h	25 - 40 m³/h
Working Pressure	≤0.6 MPa		
Pressure Loss	≤0.05 MPa		
Filtration rate	According to design Specifications		
Backwash Water Consumption	<1%		

### Technical Parameters

Model	JKQF48-1	JKQF48-2	JKQF48-3	JKQF48-4	JKQF48-5	JKQF48-6
Inlet and Outlet Diameter (mm)	(100)	200	200	200	200	200
Sewage Duct Diameter (mm)	(80)	100	100	100	100	100
Flow (m³/h)	15-50	30-100	45-150	60-200	75-250	90-300
Max Working Pressure (MPa)	0.6(1.0)	0.6(1.0)	0.6(1.0)	0.6(1.0)	0.6(1.0)	0.6(1.0)
Filter area (m²)	1.13	2.26	3.39	4.52	5.65	6.78
Overall length (mm)	(1320)	2640	3960	5280	6600	1920
Quartz sand (t)	0.6	1.2	1.8	2.4	3	3.6
Drain valve interface	4" ×3"	4" ×3"	4" ×3"	4" ×3"	4" ×3"	4" ×3"

### Operation Principle

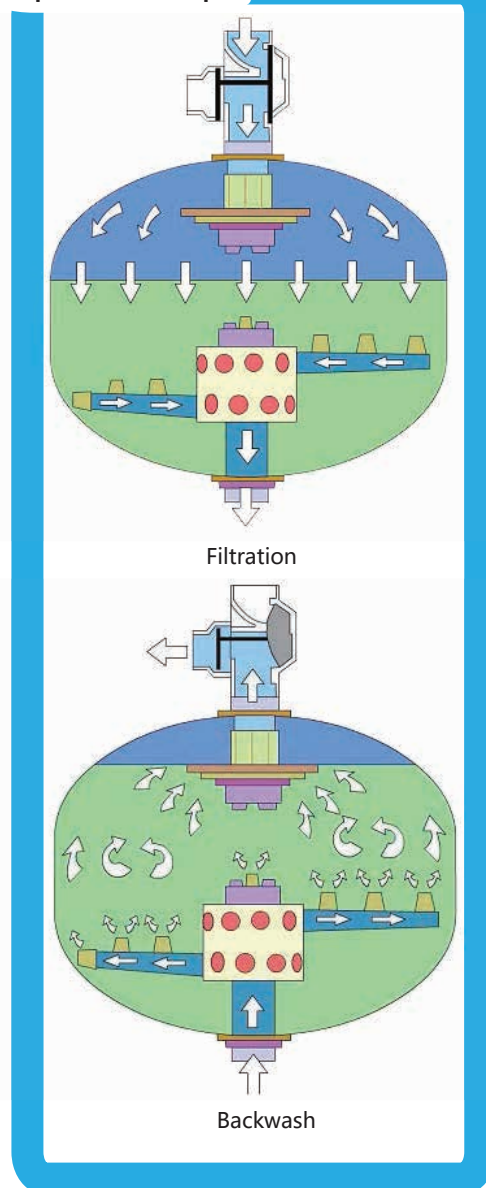

### Application

- Raw water filtration
- Water filtration supplement
- circulating water bypass filtration
- low turbidity(≤100mg/L)filtration
- Recycled water filtration
- agriculture and irrigation filtration



# CARTRIDGE FILTER



## Technical Advantages

- ✓ Cartridge filter is designed specifically for use in power plants, providing an effective removal of iron oxide particles while still allowing for an effective backflush with compressed air and water.
- ✓ Cartridge filter is constructed of quality polypropylene media and heat melted without adhesives, thereby it has wide chemical compatibility and excellent corrosion resistance.
- ✓ The unique pleat design enhances element surface area and extends element service life while maintaining superior solid contamination removal efficiency.
- ✓ Uniform flow distribution yields maximum flow rate at low resistance and longer operation life and protects against pleat collapse and bunching.



JKU-E High Flow Cartridge Filter

No.	Item	Specifications
1	OD	6 inches, 6.5 inches, 7 inches
2	Length	20 inches, 40 inches, 60 inches, 80 inches
3	Material	Media & Core Material Polypropylene (PP)
		End Cap Material Polypropylene (PP)
		O-ring Material E - EPDM, B - BUNA-N, V - VITON, S - SILICONE
4	Connection Type	T - Kangjie Standard Type, P - P Type, M - M Type, H - H Type, D - Customized Type
5	Micron Rating (≥99.9%)	1 μm, 5 μm, 10 μm, 20 μm, 40 μm, 75 μm, 100 μm
6	Recommended Change-out Differential Pressure	0.25 MPa@25 °C
7	Maximum Operating Temperature	80 °C (Max. 0.15 MPa@80 °C)



JKU-P High Performance Cartridge Filter

No.	Item	Specifications
1	OD/ID/Length	2.5 inches/1.3 inches/10~40 inches
		Media & Core Material Polypropylene (PP)
2	Material	Outer Sleeve & End Cap Material Polypropylene (PP)
		O-ring Material E - EPDM, B - BUNA-N, V-VITON, S-SILICONE
3	Connection Type	1 - DOE, 2 - 222/flat, 3 - 222/fin, 4 - 226/flat, 5 - 226/fin
4	Micron Rating	0.45 μm, 1 μm, 2 μm, 3 μm, 5 μm, 10 μm, 20 μm
5	Recommended Change-out Differential Pressure	0.2 MPa@25 °C
6	Maximum Operating Temperature	80 °C (Max. 0.15 MPa@80°C)



**JKU-C Backflushable Cartridge Filter**

No.	Item	Specifications
1	OD/ID/Length	68 mm/34 mm/1782 mm
2	Material	Media & Core Material Polypropylene (PP)
		Cage & End Caps Material Polypropylene (PP)
		O-ring Material E - EPDM, B - BUNA-N, V - VITON, S - SILICONE
3	Connection Type	Top 304SS Thread (3/8-16UNC)
		Bottom Thread (1 1/2-12UNF)
4	Micron Rating@Efficiency	Normal Operation: 1 µm@95% ~ 5 µm@99.5%
		Boiler Start-up: 10 µm@99.9% ~ 30 µm@99.9%
5	Maximum Operating Temperature	0.25 MPa@65 °C
6	Maximum Operating Differential Pressure	80 °C (Max. 0.15 MPa@80 °C)



**JKU-PH High Performance Cartridge Filter**

No.	Item	Specifications
1	Material	Media & Core Material Polypropylene (PP)
		End Cap Material Polypropylene (PP)
		Outer Sleeve Polypropylene (PP)
		O-ring Material E - EPDM, B - BUNA-N, V-VITON, S-SILICONE
2	OD/ID/Length	2.25 inches/1.125 inches/20 &40 inches
		2.5 inches/1.125 inches/20 &40 inches 2.5 inches/1.375 inches/20 &40 inches
3	Connection Type	1 - DOE, 2 - 222/flat, 3 - 222/fin, 4 - 226/flat, 5 - 226/fin
4	Micron Rating	3 µm, 5µm, 10µm, 20µm, 40µm
5	Recommended Change-out Differential Pressure	0.1 MPa@25 °C
6	Maximum Operating Temperature	80 °C (Max. 0.15 MPa@80 °C)

**Ordering Guide**

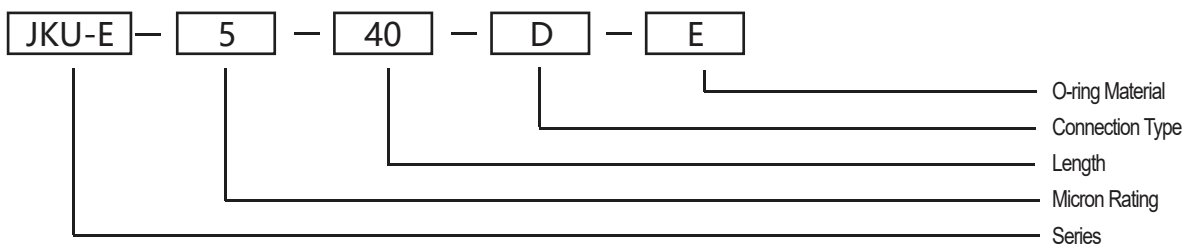

# CERTIFICATION

